

# RUMFORD 1000

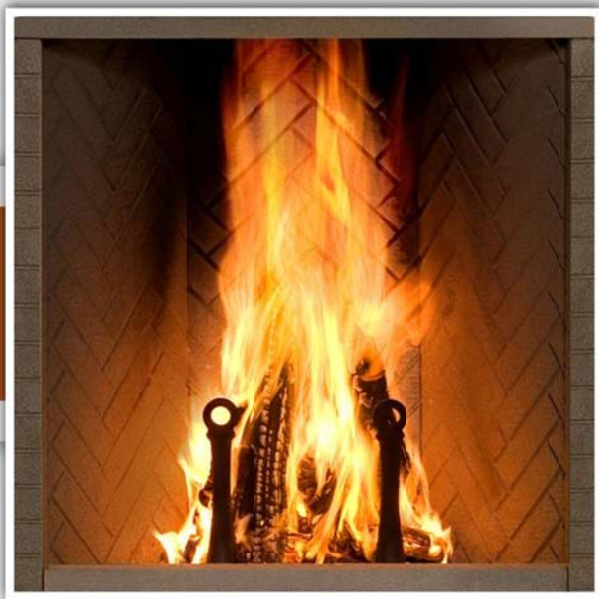

CLEAN DOESN'T MEAN COMPROMISE

**Dear Customer,**

The Renaissance Rumford™ 1000 is the world's first certified clean burning open fireplace. It combines technology with elegance, allowing you to enjoy an open fire without compromising environmental quality.

We have designed your new Renaissance Rumford™ 1000 to be easy to install, operate and maintain. It is in your best interest to become familiar with it. Study your manual to be sure that the installation is correct, and then follow the guidelines for operation and maintenance.

We at Renaissance Fireplaces™ congratulate you on your choice of the Rumford 1000, and are confident that you have purchased a fireplace that burns cleanly, without compromise.

Sincerely,

Renaissance Fireplaces™ Team

August 2008

---

## TABLE OF CONTENTS

---

<b>SAFETY FIRST</b>	<b>3</b>
<b>DO'S AND DONT'S</b>	<b>3</b>
<b>CREOSOTE: FORMATION AND REMOVAL</b>	<b>4</b>
<b>FUEL WOOD</b>	<b>4</b>
<b>GENERAL SPECIFICATIONS</b>	<b>5</b>
<b>OPTIONS</b>	<b>5</b>
<b>UNIT DIMENSIONS AND CLEARANCES</b>	<b>6</b>
<b>INSTALLATION</b>	<b>10</b>
<b>LOCATION</b>	<b>10</b>
<b>CEILING CLEARANCE</b>	<b>10</b>
<b>UNPACKING YOUR RUMFORD 1000</b>	<b>13</b>
<b>MOVING THE RUMFORD 1000</b>	<b>14</b>
<b>SECURING THE FIREPLACE IN PLACE</b>	<b>14</b>
<b>DOOR AND FIRESCREEN INSTALLATION</b>	<b>15</b>
<b>FINISHING COVERS INSTALLATION</b>	<b>16</b>
<b>SURROUND LINTELS INSTALLATION</b>	<b>17</b>
<b>OUTSIDE AIR DUCT</b>	<b>17</b>
<b>CHIMNEY</b>	<b>19</b>
<b>CHIMNEY INSTALLATION</b>	<b>20</b>
<b>OFFSET CHIMNEY</b>	<b>20</b>
<b>CHASE ENCLOSURE</b>	<b>22</b>
<b>FRAMING</b>	<b>22</b>
<b>FIREPLACE FACING</b>	<b>22</b>

HEARTH EXTENSION	24
MANTEL	27
FIREBOX LINING INSTALLATION	27
<b>OPERATION</b>	<b>34</b>
OUTSIDE AIR CONTROL	34
LIGHTING THE RUMFORD 1000	34
CONTROLLING YOUR FIRE	34
REFUELING	36
GUILLOTINE DOOR	36
GUILLOTINE FIRESCREEN	36
<b>MAINTENANCE</b>	<b>37</b>
GENERAL CLEANING	37
PAINT	37
GLASS CLEANING	37
CHIMNEY CLEANING	37
DISPOSAL OF ASHES	38
GUILLOTINE SYSTEM	38
GUILLOTINE DOOR'S SEAL	38
<b>LISTING LABEL</b>	<b>41</b>
<b>REPLACEMENT PARTS</b>	<b>41</b>
<b>30 YEAR LIMITED WARRANTY</b>	<b>42</b>

---

## SAFETY FIRST

---

### Do's AND DONT'S

If this fireplace is not properly installed, a house fire could result. For your safety, follow the installation directions. Contact your local authority having jurisdiction (such as municipal building department or fire department) regarding restrictions and installation requirements, and the need to obtain a permit.

To ANYONE using this fireplace: these **DO's** and **DONT's** are for your safety.

1. **DO** read this instruction manual before lighting your first fire. **DO** keep these instructions for future use.
2. **DO** burn seasoned wood fuel.
3. To avoid glass breakage, **DO NOT** slam the fireplace door.
4. **DO NOT** ever use gasoline, gasoline-type lantern fuel, kerosene, charcoal lighter fluid or similar liquids to start or freshen up a fire in this fireplace. Keep all such liquids well away from the fireplace while it is in use.
5. **DO NOT overfire the fireplace.** Burn a maximum of 4 medium logs (5" diameter) or 3 large logs (6" diameter) at a time. See complete warning on page 34.
6. **DO operate the fireplace with the door either fully closed or fully open with the firescreen.** If the door is left partly open for more than a couple of minutes, it will increase the burn rate to dangerous levels and permanently damage the fireplace.
7. If you use the fireplace with the door wide open, **DO NOT** forget to bring the firescreen down to prevent logs and sparks from burning your floor. Under no

circumstances should the fireplace be used without either the firescreen or the door closed.

8. **DO** keep all combustible materials (furniture, firewood, etc.) at least 4' away from the front of the fireplace.
9. **DO NOT** use a fireplace grate or other products not specified for use with this fireplace.
10. **DO NOT** step or put legs of a step ladder on the metal front step or the hearth threshold.



**NOTE:** We strongly recommend that our products be installed and serviced by professionals who are certified by the National Fireplace Institute in the U.S. or by Wood Energy Technology Transfer Inc. in Canada.



## CREOSOTE: FORMATION AND REMOVAL

When wood is burned slowly, it produces tar and other organic vapors which combine with the expelled moisture from the wood to form creosote. The creosote vapors can condense in the relatively cool chimney of a slow burning fire. When ignited, this creosote makes an extremely hot fire. The chimney should be inspected periodically during the heating season to see if a creosote build-up has occurred. If a significant layer of creosote has accumulated ( $\frac{1}{4}$ " or more), it should be removed to reduce the risk of chimney fire.

## FUEL WOOD

We recommend always burning your fireplace with seasoned wood logs. Do not use construction scraps (e.g. 2x4 or plywood scraps) as your only supply of fuel as you can overheat and seriously damage the fireplace.

---

**WARNING: BURN DRY WOOD ONLY.  
DO NOT BURN DRIFTWOOD, TREATED WOOD, COAL, GARBAGE, OR PLASTIC.**

---



If you use densified wood logs, do not use more than two at a time and only with the firescreen closed. If you use more than two at a time, you will overfire the fireplace.

If you use wax fuel logs (e.g. Duraflame), do not use more than one wax fuel log at a time and only with the firescreen closed. Using them with a closed door will lead to a dirty glass. Furthermore, if you use more than one at a time, you will overfire the fireplace.

Use only firelogs that have been evaluated for fireplace use. In Canada, they should meet the requirements of ULC/ORD-C127-M1990. Refer to the firelog warnings and caution markings prior to use.

---

## GENERAL SPECIFICATIONS

---

The RUMFORD 1000 fireplace is environmentally friendly and provides a magnificent view of the fire.

When lined with the optional vermiculite panels, it has met the United States Environmental Protection Agency (EPA) Wood Burning Fireplace Program Phase 2 emission level. It is:

- Typically burning at a rate of 4 kg/hr,
- Clean burning with an emission rate of 3.0 g/kg when burned with the door open and the firescreen closed as tested with ASTM 2558<sup>1</sup> test protocol,
- Clean burning with an emission rate of 1.0 g/kg when burned with the door closed as tested with ASTM 2558<sup>1</sup> test protocol,
- Clean burning with an equivalent emission rate of 4.19 g/hr when burned with the door closed, and
- An exempt fireplace when tested as per the EPA Stove test protocol. It then obtained a burn rate well above 5kg/h.

### OPTIONS

The RUMFORD 1000 has two options for the bricks that line the interior of the firebox. One of the two options **MUST** be installed.

1. Vermiculite panels with a herringbone brick pattern (EO-VP1000). This choice offers the cleanest burning fireplace on the market and a very classic herringbone look.

Pros: super low emissions, very fast startup.

Cons: Less durable than cement refractory bricks, expect to see wear and cracking with these bricks over time.

2. Cement refractory bricks with a running bond brick pattern (EO-RB1000) which offers the most durable solution for the Rumford and a very traditional look.

Pros: Durable and dependable, less maintenance and degradation over time.

Cons: The fireplace will not light as quickly.



---

**WARNING: THIS FIREPLACE HAS NOT BEEN TESTED WITH AN UNVENTED GAS LOG SET. TO REDUCE RISK OF FIRE OR INJURY, DO NOT INSTALL AN UNVENTED GAS LOG SET INTO THIS FIREPLACE. DO NOT INSTALL A GAS LIGHTER BECAUSE THE HEAT PRODUCED BY THE FIREPLACE MAY PERMANENTLY DAMAGE THE GAS LIGHTER**

---

---

<sup>1</sup> ASTM 2558: Standard Test Method for Determining Particulate Matter Emissions from Fires in Low Mass Wood-Burning Fireplaces.

# UNIT DIMENSIONS AND CLEARANCES

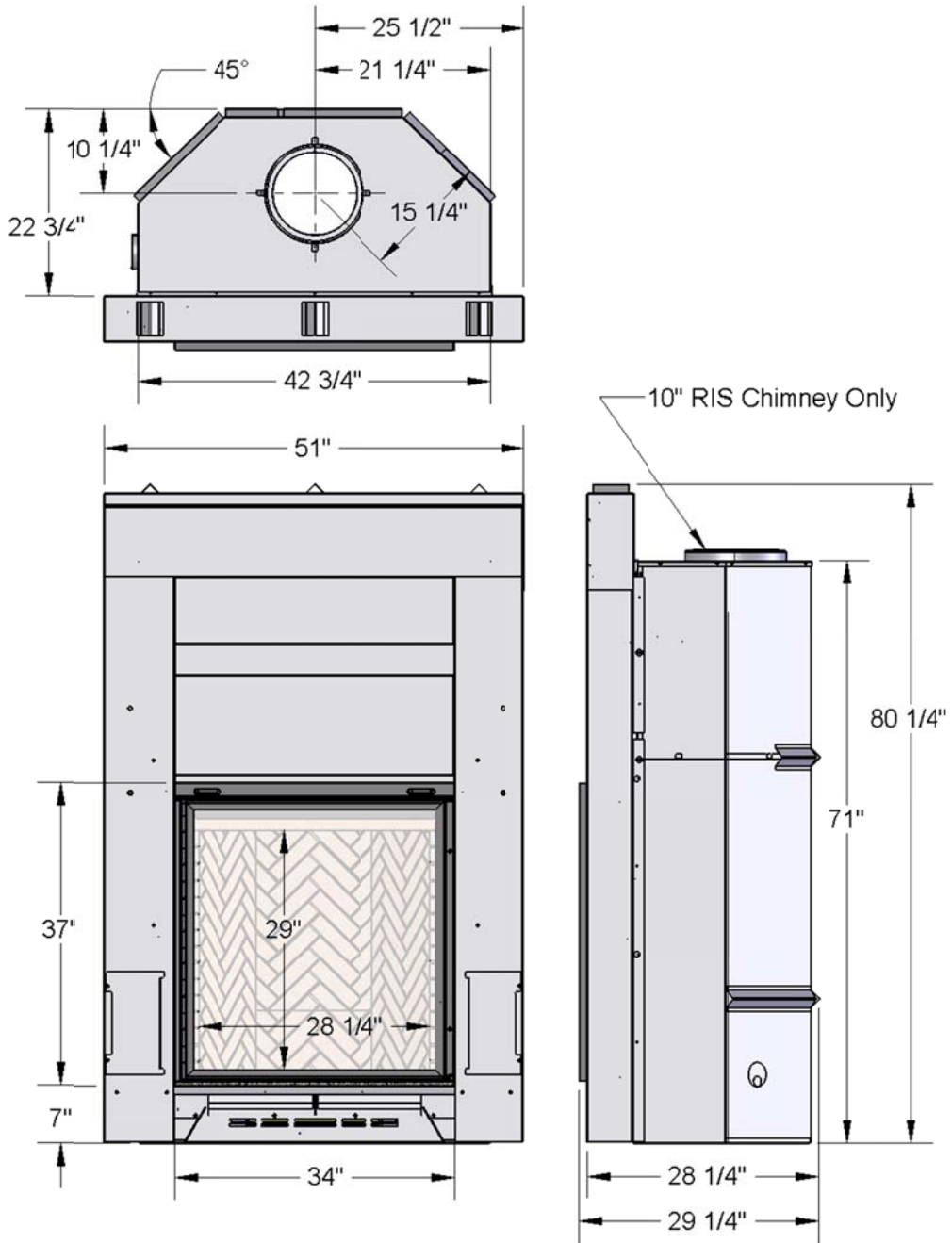
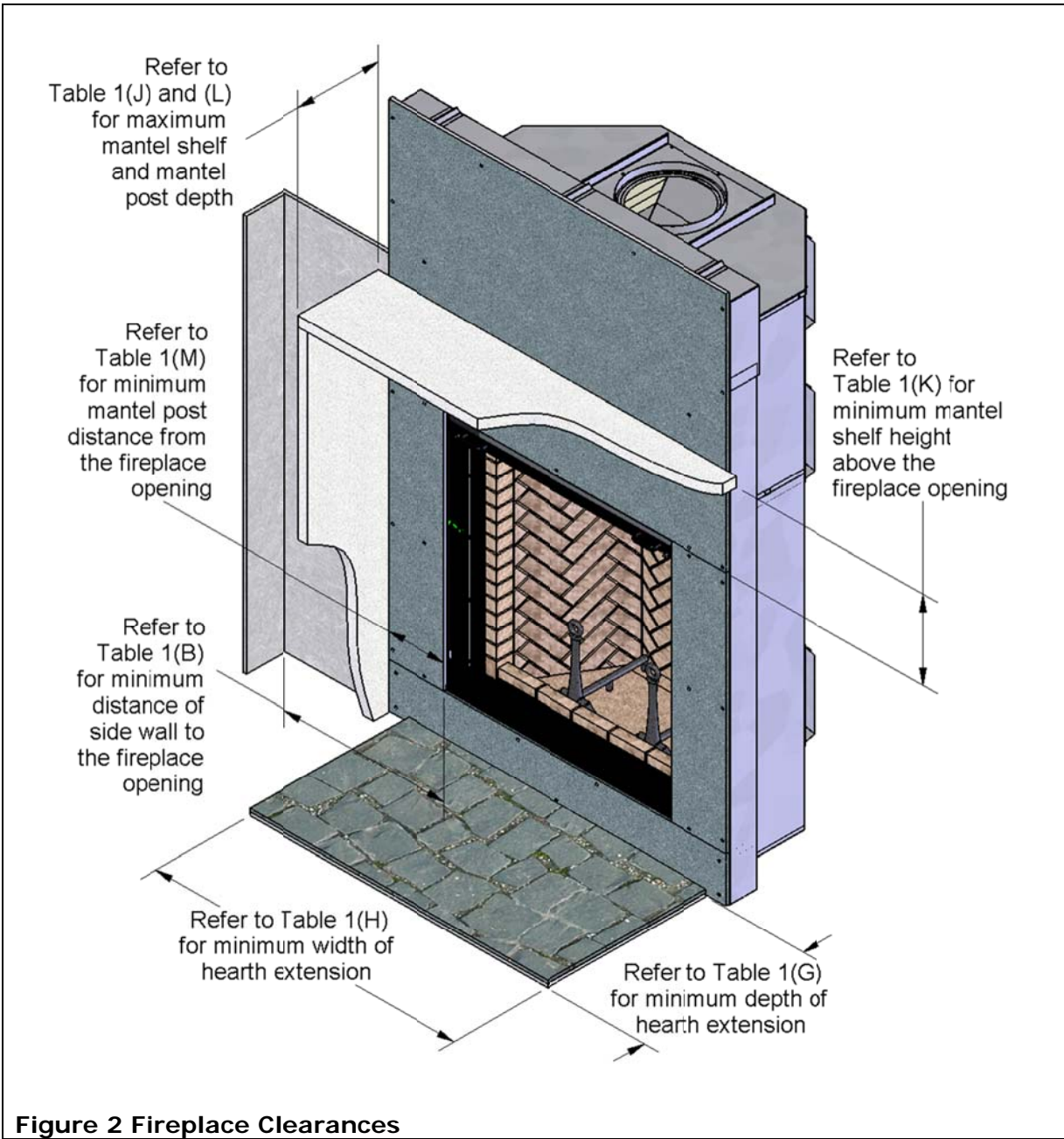

Figure 1 Fireplace Dimensions





**Table 1 Unit Clearances and Specifications**

A	Distance to combustible material from side, back and top standoffs	0" (0.0 mm)
B	Minimum distance from side wall to the side of the fireplace opening	24" (610 mm)
C	Minimum ceiling clearance: from the base of the fireplace to the ceiling	8' (2.44 m)
D	Minimum chimney height: minimum total chimney height from fireplace top to below the chimney rain cap	12' (3.66 m)
E	Maximum chimney height: maximum total chimney height from fireplace top to below the chimney rain cap	60' (18.3 m)
F	Maximum chimney height supported by the fireplace	15' (4.6 m)
G	Minimum depth of non-combustible hearth extension: from the front of the fireplace (refer to the "Installation: Hearth Extension" section for details)	24" (610 mm)
H	Minimum width of non-combustible hearth extension: total width, must be centered on the firebox opening (refer to the "Installation: Hearth Extension" section for details)	45" (1.14 mm)
I	Minimum width of the spark guard	45" (1.14 mm)
J	Maximum mantel shelf depth (see Table 2 for other mantel sizes)	12" (305 mm)
K	Minimum height of a combustible mantel shelf above the top of the fireplace opening (to the bottom of the combustible mantel) (refer to the "Installation: Mantel" section for details)	See Table 2
L	Maximum mantel post depth (see Table 3 for other mantel post sizes)	12" (305 mm)
M	Minimum distance between each combustible mantel post and the fireplace opening (refer to the "Installation: Mantel" section for details)	See Table 3



**Table 2 Various Mantel Shelf Depths and Corresponding Installation Heights**

Maximum Mantel Shelf Depth	Minimum Installation Height
0" to 6"	6"
12"	12"

A combustible mantel shelf cannot be installed less than 6" above the top of the fireplace opening. A combustible mantel shelf cannot be deeper than 12".

For combustible mantel shelf depths between 6" and 12", simply install the mantel shelf at a distance above the fireplace opening corresponding to the mantel shelf depth:

- For example, mantel shelf depth to be installed: 9 ¼"
- It is between 6" and 12"
- Minimum installation height of a 9 ¼" mantel: **9 ¼"** above the fireplace opening.

If the combustible mantel shelf has a cross-section with variable depth, it has to be installed so that its widest part is not installed lower than the corresponding minimum installation height while making sure that the lowest point of the mantel shelf is not installed lower than the minimum installation height corresponding to its depth.

Refer to the "Installation: Mantel" section for particulars.

**Table 3 Various Mantel Post Depths and Corresponding Installation Distance**

Maximum Mantel Post Depth	Minimum Installation Distance
0" to 3"	6"
12"	10"

A combustible mantel post cannot be installed less than 6" from either side of the fireplace opening. A combustible mantel post cannot be deeper than 12".

For combustible mantel post depths between 6" and 12", you can calculate the minimum installation distance between the two mantel posts given as follows:

- For example, mantel post depth to be installed: **9 ¼"**
- It is between 3" and 12"
- So:  $(9.25 \times 4/9) + 4.676 = 8.778 = 8 \frac{13}{16}"$
- Minimum installation distance of a 9 ¼" mantel post: **8 13/16"** from either side of the fireplace opening.

If the combustible mantel post has a cross-section with variable depth, it has to be installed so that its thickest part is not installed closer than the corresponding minimum installation distance while making sure that the thinnest point of the mantel post is not installed closer than the minimum installation distance corresponding to its depth.

Refer to the "Installation: Mantel" section for particulars.

## INSTALLATION

Check with your local authority having jurisdiction (such as municipal building department, fire department, fire prevention bureau, etc.) regarding restrictions and installation requirements, and the need to obtain a permit.

**WARNING: IF THIS FIREPLACE IS NOT PROPERLY INSTALLED, A HOUSE FIRE CAN RESULT. FOR YOUR SAFETY, FOLLOW THE INSTALLATION INSTRUCTIONS AND CLEARANCES. DO NOT PACK REQUIRED AIR SPACES WITH INSULATION OR OTHER MATERIALS.**



### LOCATION

The RUMFORD 1000 must be installed within the vapor barrier of the home. Preferably the whole fireplace should be within the vapor barrier but at the very least, the front of the fireplace should be part of the wall including the vapor barrier. It cannot be installed outside, or on a three season porch.

Your RUMFORD 1000 fireplace may be installed in different ways (see Figure 3) without any special floor reinforcement.

Specifications of the fireplace along with clearances are shown in Figure 1, Figure 2, Table 1, Table 2 and Table 3. We recommend that you take the time to plan your entire installation (fireplace and chimney) before beginning the actual installation (refer to Figure 4).

1. Note the location of roof and floor joists. Try to choose a location that does not require cutting them.
2. Do not build shelves or cupboards in the area above the fireplace. This space must be kept empty.
3. If at all possible, install the chimney on the interior of the building as it will provide better performance than an exterior chimney. In areas with continuous temperatures below 32°F the use of an exterior chimney may result in operating problems such as poor draft and excessive condensation of combustion products. If you do install an exterior chimney we recommend that you install it within an insulated enclosure (see Installation: Chase Enclosure).

### CEILING CLEARANCE

Ceiling clearance is the distance from the base of the fireplace to the ceiling.

Under no circumstances should the distance between the ceiling firestop and the base of the fireplace be less than the clearance specified in Table 1 (C).

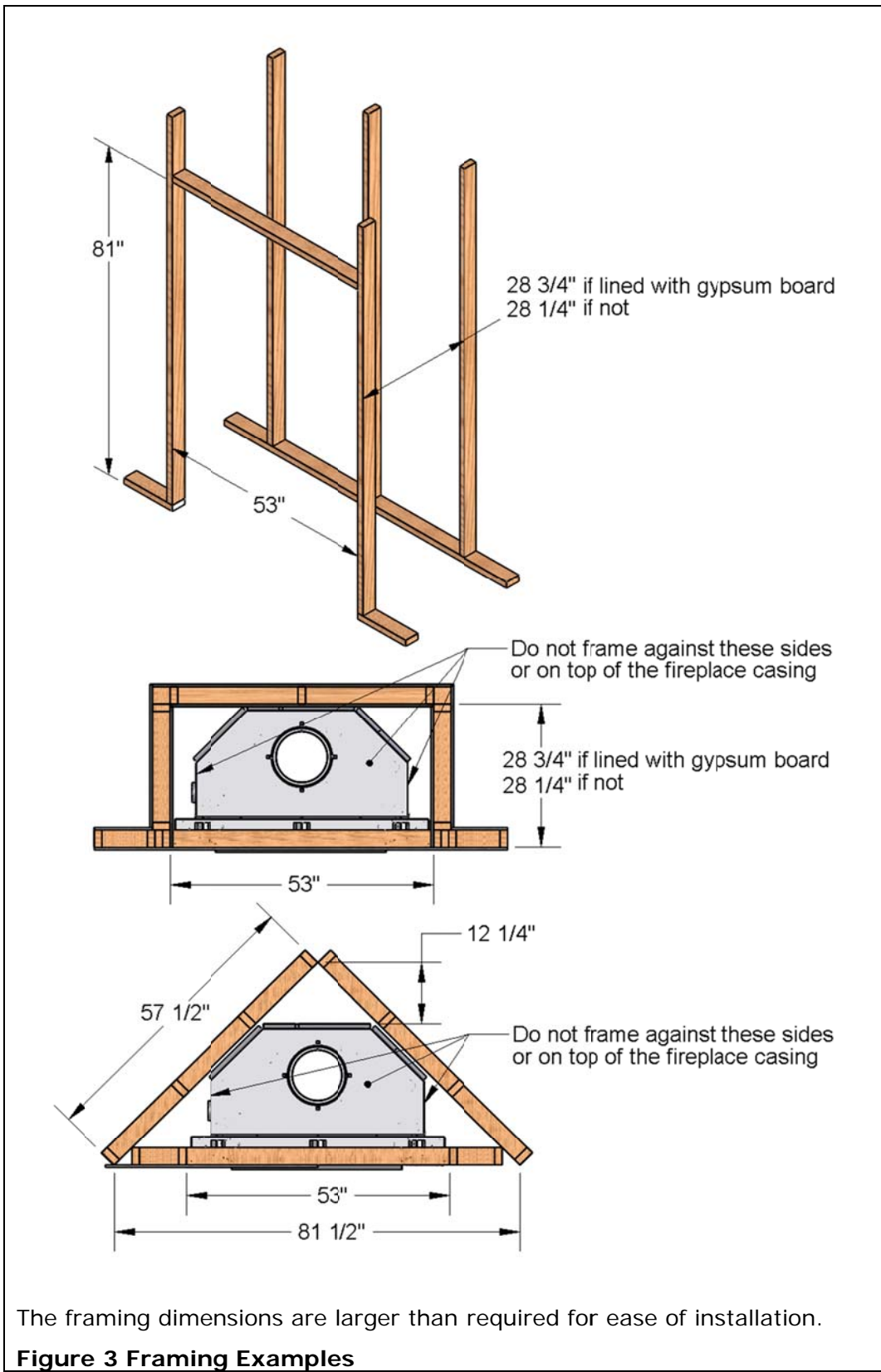

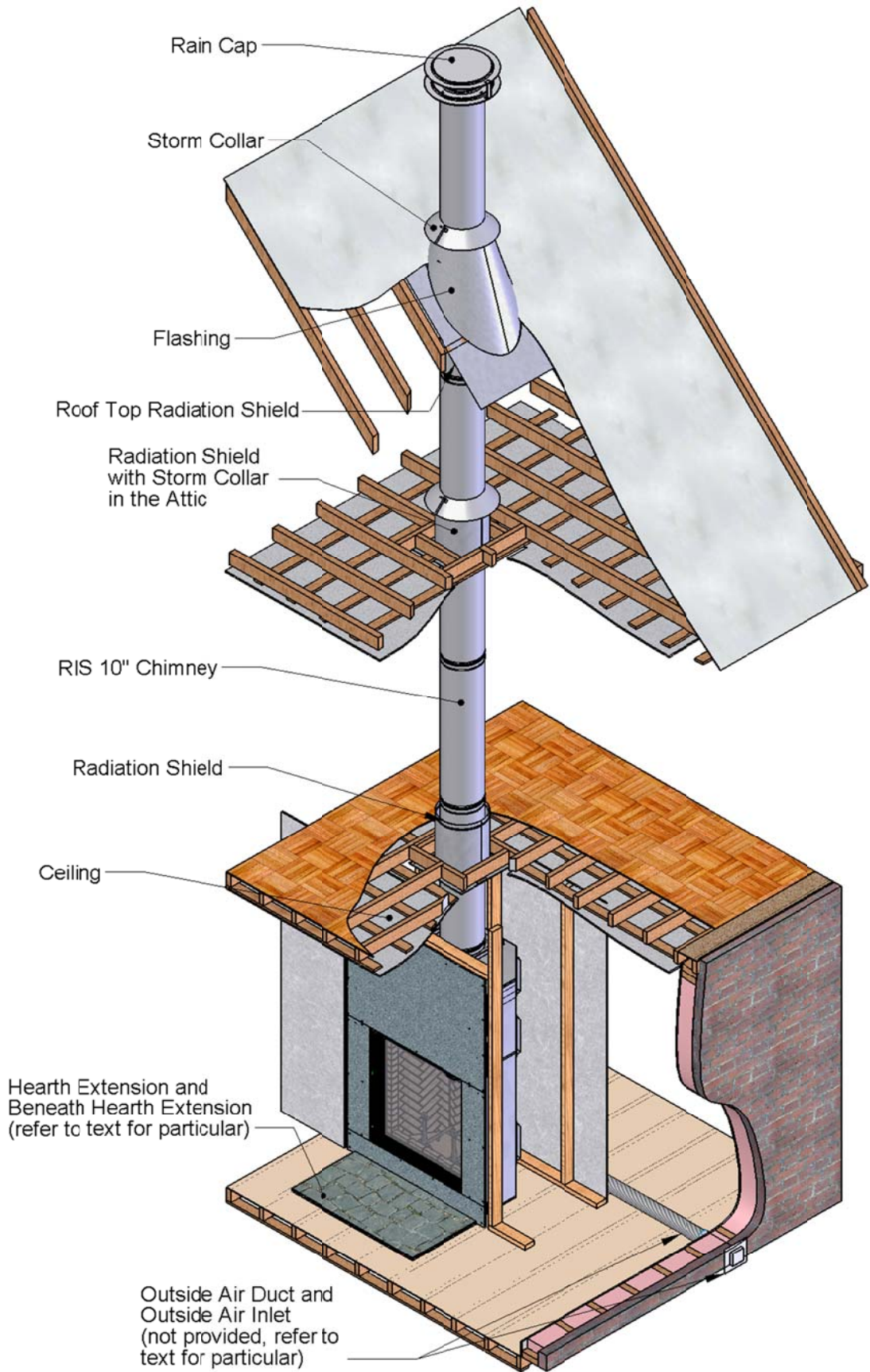

**Figure 4 General Installation**

## UNPACKING YOUR RUMFORD 1000



**WARNING: THE FIREPLACE IS FRONT HEAVY. MAKE SURE TO ALWAYS MAINTAIN CONTACT WITH THE FIREPLACE WHEN MOVING IT TO PREVENT ANY UNDUE TILTING.**

The RUMFORD 1000 fireplace is front heavy. To safely ship and transport the RUMFORD 1000, we have taken various parts from the front of the fireplace and attach them to the back of the crate rendering the overall crate rather well-balanced. As soon as you start removing heavy parts from the back of the crate, the rest of the crate becomes unbalanced, be careful.

Two transportation blocking brackets are in place to prevent the guillotine door from moving during shipping. Do not attempt to move the guillotine door before removing these transportation safety devices. To remove some weight on the front of the fireplace, the counterweights are not installed; they are attached to the back of the crate. We recommend that you wait until the fireplace is in its final position before removing the transportation blocking brackets and installing the counterweights. Until you do, the guillotine door is disabled.

The fireplace crate includes all of the following:

- (A) One fireplace complete with a glass door (approximately 500 lb);
- (B) Four small brackets securing the fireplace to the crate: keep them, they will be necessary for securing the fireplace to the floor;
- (C) One top finishing cover in transport position on the fireplace;
- (D) One front top finishing cover;
- (E) Three black lintels wrapped in paper;
- (F) Two bigger counterweights: attached to the back vertical posts of the crate (approximately 25 lb each);
- (G) One smaller counterweight: attached to the back vertical posts of the crate (approximately 10 lb);
- (H) A pair of Renaissance andirons: in the fireplace firebox;
- (I) A hearth threshold in three parts;
- (J) One spark guard: attached to the back of the fireplace;
- (K) One anti-tip stability bracket: attached to the top of the fireplace casing;
- (L) In the manual bag (attached to the left side of the fireplace casing, close to the base):
  - Two counterweight blocking rods;
  - One bag with four large self-tapping screws;
  - One bag with 17 rivets;
  - Some high temperature grease;
  - An owner's and installation manual.
  - Two black round caps;
  - One bag with 15 small self-tapping screws;
  - A removable door handle;
  - A 5" external air coupling;

These items will be referred to by the above letters throughout the installation instructions of the fireplace itself.



## MOVING THE RUMFORD 1000

**WARNING: THE FIREPLACE IS FRONT HEAVY. MAKE SURE TO ALWAYS MAINTAIN CONTACT WITH THE FIREPLACE WHEN MOVING IT TO PREVENT ANY UNDUE TILTING.**



The fireplace arrives with two transportation handles, one on each side of the fireplace. They are solidly attached and can be used to lift and transport the fireplace without the pallet. Moving straps or dollies can also be used. Always handle the fireplace by its casing. The front of the fireplace, or guillotine bay, cannot be used to lift the rest of the fireplace. The RUMFORD 1000's main body weighs 500 lb as shipped.

You can use an Escalera to move the fireplace. If you do, make sure to position the attachment straps at the locations shown in Figure 5. Do not put the attachment straps anywhere else or you will damage the guillotine system by doing so.

**Be aware that once the RUMFORD 1000 is removed from its pallet it cannot be moved from the side because you will damage the guillotine bay that is wider than the rest of the fireplace.**

If needed, you can reduce the weight of the fireplace by removing the glass door (50 lbs).

If you decide to remove the glass door, you need to remove the top finishing cover (see step 1 on page 15) to allow you to open the firescreen. Open the firescreen and lock it in position. Before continuing, make sure that the guillotine door is locked in its transportation position by the two brackets.

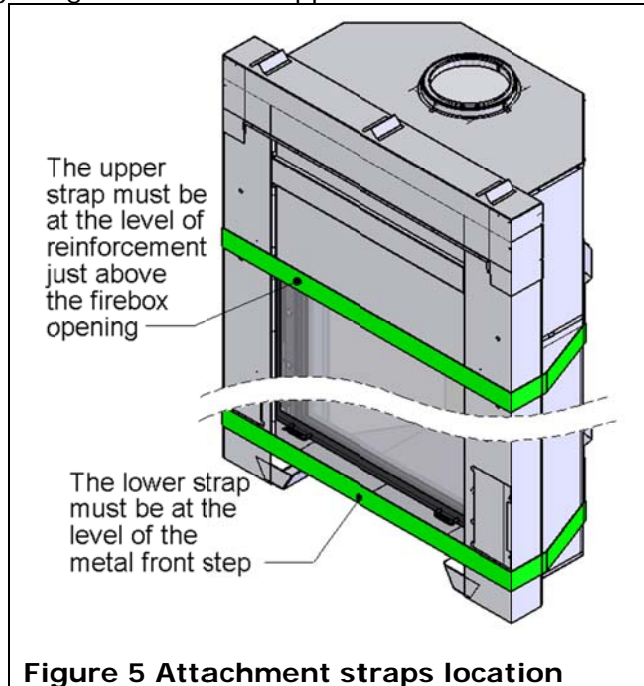

**WARNING: YOU WILL PERMANENTLY DAMAGE THE GUILLOTINE SYSTEM IF YOU ATTEMPT TO REMOVE THE GLASS DOOR WHILE THE GUILLOTINE SYSTEM IS UNLOCKED.**



Unlock the glass door (see Figure 31) and open it. Either have someone hold the glass door or place a cushion under it to hold it open. Using a  $\frac{5}{32}$ " Allen key, remove the five screws holding the hinge to the guillotine frame. Start by the bottom and move your way up. Be cautious not to drop the glass door once you start unscrewing the last screw. Get a good hold of the glass door and move it to a secure location. Close the firescreen.

### SECURING THE FIREPLACE IN PLACE

The fireplace **MUST** be solidly attached to both the floor and to the back wall.

Using the four small brackets (B) that were securing the fireplace to the crate, attach the casing of the fireplace to the floor. Position the brackets all around the fireplace in the same fashion as they were on the crate. If possible, try to have the brackets screwed into the floor joists with 2" wood screws.

Also install the anti-tip stability bracket (K). It must be solidly screwed to the back wall and to the top of the fireplace. Depending on your specific installation, you can install the anti-tip stability bracket in two different ways. Refer to Figure 6 for examples of installation of the anti-tip stability bracket. Use the four large self-tapping screws provided (L) to attach the anti-tip stability bracket to the top of the fireplace casing.

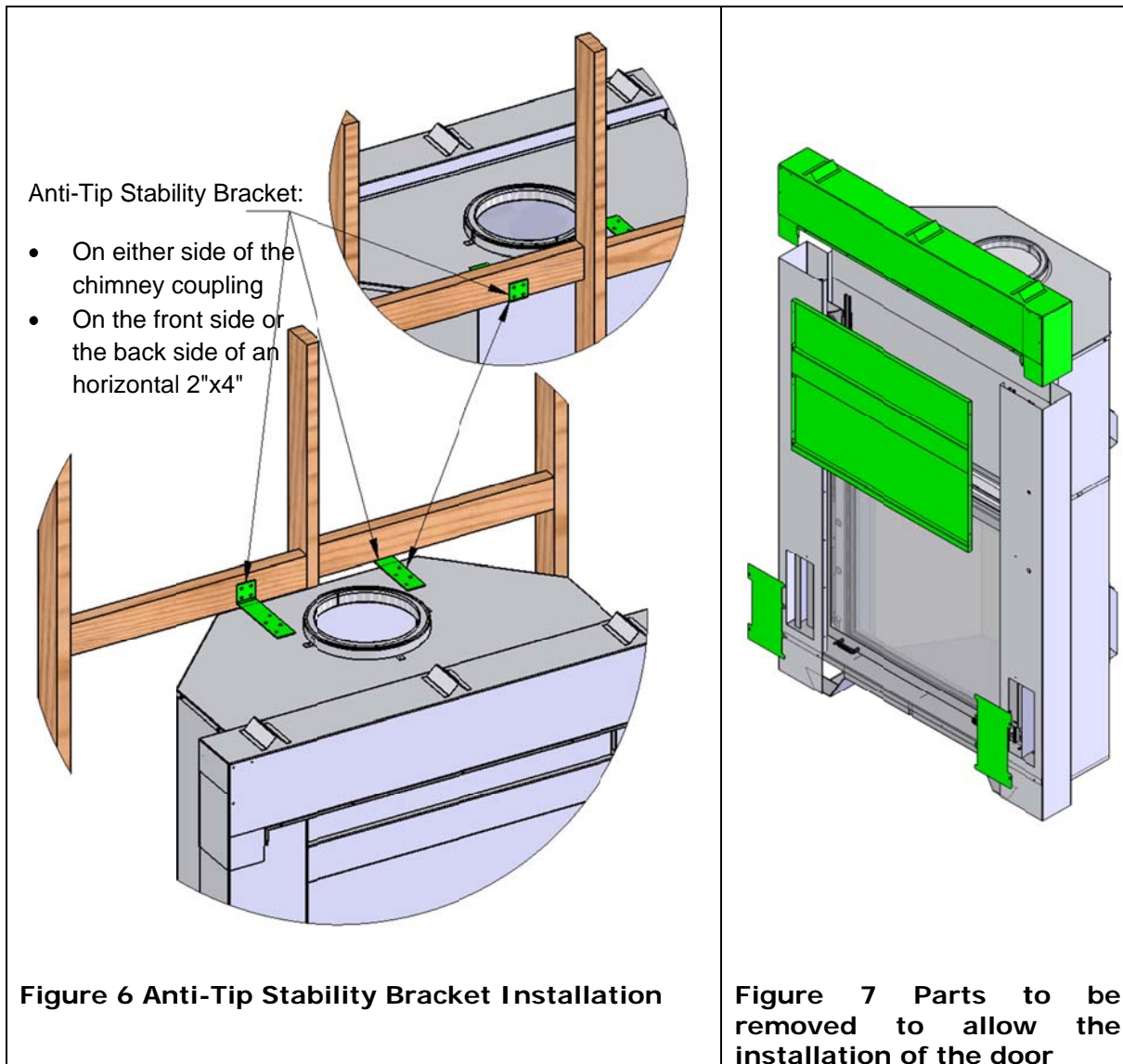

## DOOR AND FIRESCREEN INSTALLATION

Now that the fireplace is correctly positioned, you can finish unpacking the guillotine system. Start by completing the installation of the guillotine door.

1. To be able to install the counterweights (F) some parts need to be removed and reinstalled later (see Figure 7). Take the time to notice how they are installed and keep all the screws. Start by removing the top finishing cover. It is held in place by two screws, one on either side. Before removing the screws, take note how the top finishing cover is installed. It must be reversed, so the front faces towards the back when it is reinstalled. Remove the two screws and remove the top finished cover. Then remove the front central finishing cover. Continue by removing both left and right access doors for the counterweights.
2. Grab the firescreen with both hands and lift it straight up. Be careful not to drop it, there is no counterweight or latch. Use a piece of wood about 39" long to keep the firescreen open.
3. Find the two bigger counterweights (F), the two counterweight blocking rods and the two black round caps from the manual bag (L).



4. Start on the right side. Undo the knot in the cable around the back right pulley and slip it through the pulley and down the counterweight channel so that on end hangs down through the bottom opening of the back counterweight channel.
5. Attach the cable to the counterweight (F) using the threaded connector and screw the threaded connector closed.
6. Locate one of the counterweight blocking rods (L), you will need it shortly.
7. Get a good hold of the other end of the cable; wear gloves for a better grip. Pull gently on the cable to insert the counterweight in the channel making sure not to tear away the felt. Pull the counterweight all the way to the top of the counterweight channel. Each counterweight weighs approximately 25 lb.
8. Push the counterweight blocking rod (L) through the hole in the counterweight channel located about 41" from the floor. Make sure to pass the blocking rod all the way through the channel and out the back. Once the rod is in place, you can let go of the counterweight cable.
9. Take the time to remove any twist the cable may have before attaching it to the frame of the guillotine door using the threaded connector.
10. Repeat steps 4 through 9 for the left door counterweight.
11. Verify that both cables are centered on their pulleys. Pull on each cable to take the weight off the counterweight and then gently remove each of the counterweight blocking rods.
12. The guillotine door is kept closed by two transportation blocking brackets. There is a blocking bracket at the bottom of the guillotine door on each side. Remove the screw holding the blocking bracket on both sides.
13. You can now install the two black round caps (L) provided over the two holes in the guillotine frame. Just push them in place.
14. The guillotine door can now be moved up and down.

Being careful not knock the firescreen off its wood support, try moving the door up and down slowly while looking at the cables and the pulleys. Make sure each cable is able to move freely and centered over its pulley. If needed, realign the pulleys. If you do so, do not forget to tighten the pulleys nut and bolts without over tightening.

15. Now undo the knot in the cable around the front right pulley and slip it through the pulley and down the front counterweight channel so that on end hangs down through the bottom opening of the front counterweight channel.
16. Attach the cable to the small counterweight (G) using the threaded connector and screw the threaded connector closed.
17. Take the time to remove any twist the cable may have before attaching it to the frame of the firescreen using the threaded connector.
18. Grab hold of the firescreen, lift it just enough to remove the wood support and bring it down slowly just enough to put tension on the cable.
19. The firescreen can now be moved up and down.

Try moving the firescreen up and down slowly while looking at the cable and the pulley. Make sure the cable is able to move freely and centered over its pulley in a straight line. If needed, realign the pulley. If you do so, do not forget to tighten the pulley's nut and bolt without over tightening.

## **FINISHING COVERS INSTALLATION**

Make sure the guillotine door and the firescreen are closed before continuing

1. Reinstall both left and right counterweight access doors (see Figure 7).
2. Reinstall the front central finishing cover (see Figure 7). Reinstall it so that the part that was facing front now faces the back as shown in Figure 8. Put it on top of the fireplace. It should rest over the two side finishing covers and flush on the front. The back edge should be on the top of the fireplace casing as shown in Figure 8. Using the two screws you removed, screw both sides of the top finishing cover to the sides. Using five of the small self-tapping screws provided (L) attach the back edge of the top finishing cover to the top of the fireplace casing.

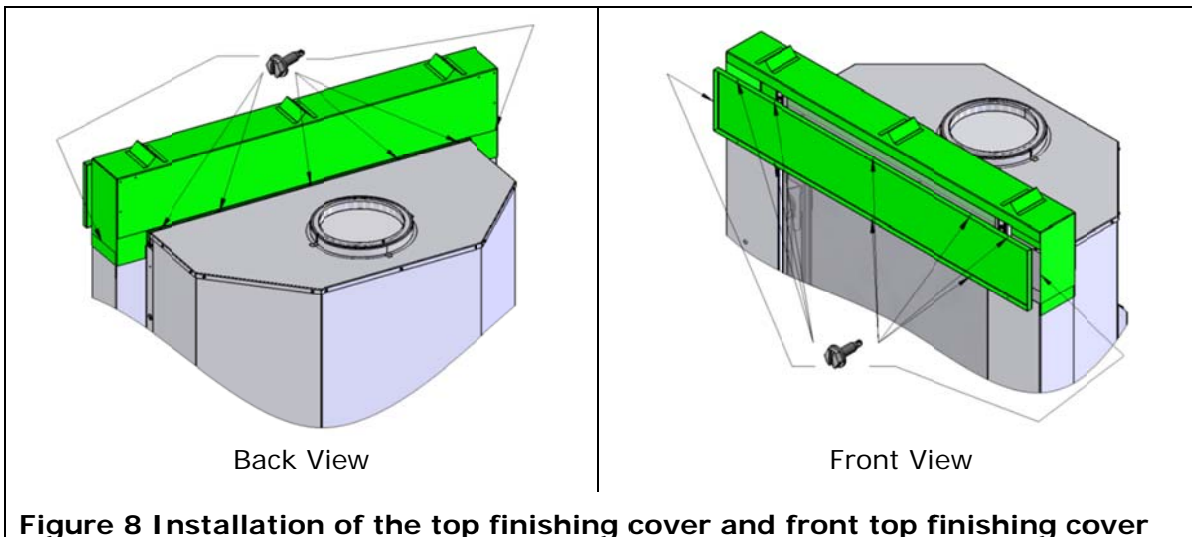

**Figure 8 Installation of the top finishing cover and front top finishing cover**

3. Using small self-tapping screws (L), install the front top finishing cover (D) as shown in Figure 8. Make sure to install the two side screws from the outside towards the inside so that the screws tips do not protrude from the side of the fireplace.

Try moving the firescreen up and down slowly to confirm that none of the screws impede its movement. Do the same for the glass door.

We recommend that both the guillotine door and the firescreen remain closed while completing the fireplace and chimney installation.

## SURROUND LINTELS INSTALLATION

Lintels are provided with the fireplace to easily finish the border of the front opening. Use the rivets provided (L) to attach the lintels to the fireplace as shown in Figure 9.

These lintels protrude past the front of the fireplace by 1" allowing ½" for the cement board panels that must cover the front and ½" for your non-combustible finishing materials.

If thicker lintels are required, though not provided, you can use the provided lintels as a template to have custom lintels made.

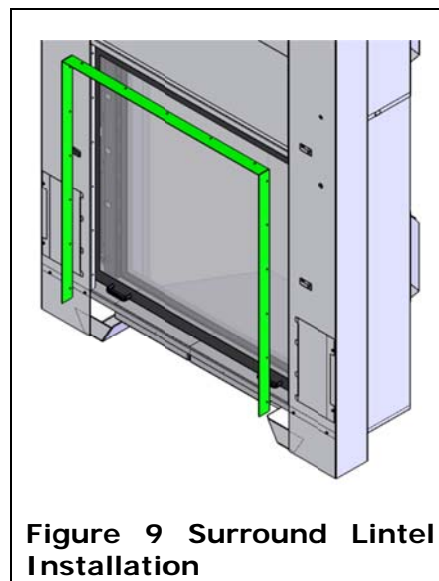

**Figure 9 Surround Lintel Installation**

## OUTSIDE AIR DUCT

After the fireplace is correctly positioned, connect the outside air inlet of the fireplace to the outside (see Figure 10).

Use an insulated aluminium flexible duct rated at over 200°F (93°C). The duct should not exceed 12' vertical rise above the base of the unit.

The air inlet should be at least 5' below the top of the chimney flue and must never terminate in attic spaces.

A 4" diameter duct can be used if the total duct run is less than 25'. For longer runs, use 5" diameter duct. Both 4" and 5" connecting sleeves are provided with the fireplace

1. Find a convenient location for the combustion air duct and outside air inlet. The outside air inlet can be above or below floor level.
2. Make a 4 ¼" (5 ¼" if using a 5" diameter duct) hole in the outside wall of the house. Push the outside air inlet in from the outside. Seal the joint between the air inlet and the outside wall with an appropriate sealant.
3. Place the insulated flexible duct over the round sleeve on the outside air inlet. At both ends, carefully pull back the insulation and plastic cover, exposing the flexible duct. Then at each end, attach the duct with metal screws to the air inlet and to the fireplace connecting sleeve. Carefully push the insulation and cover back over the duct. Tape the plastic cover in place with 2" aluminium duct tape.

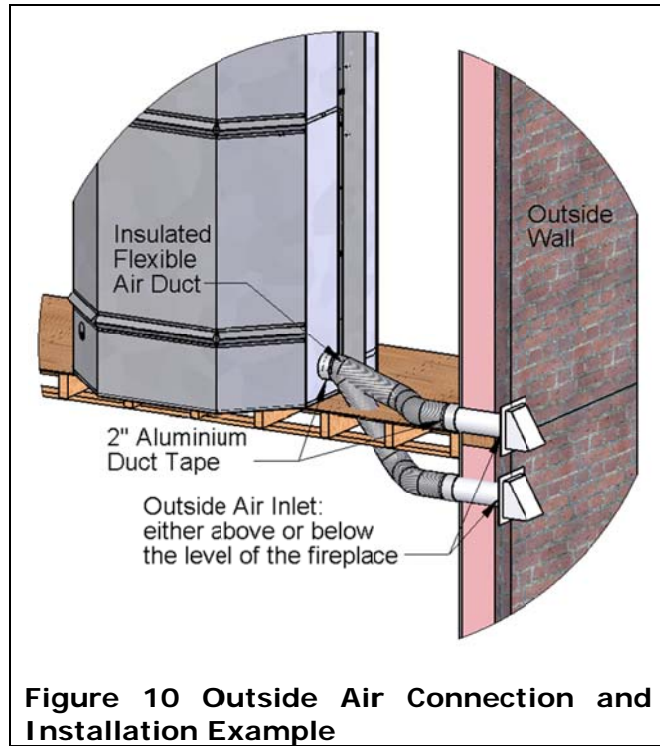

**Figure 10 Outside Air Connection and Installation Example**

**CAUTION: WHEN RUNNING THE DUCT AROUND CORNERS, BE SURE TO PREVENT CRIMPING THE DUCT THAT COULD RESTRICT THE COMBUSTION AIRFLOW.**



**Table 4 Minimum Recommended Flue Heights In Feet From The Top Of The Fireplace**

Elevation (ft)	Number Of Elbows						
	0	2 x 15°	4 x 15°	2 x 30°	4 x 30°	2 x 45°	4 x 45°
0 - 1000	12'	13'	14'	15'	18'	16'	20'
1000 - 2000	12'6"	13'6"	14'6"	15'6"	19'	16'6"	20'
2000 - 3000	13'	14'	15'	16'	19'6"	17'	21'6"
3000 - 4000	13'6"	14'6"	15'6"	17'	20'	18'	22'6"
4000 - 5000	14'	15'	16'	17'6"	21'	18'6"	23'
5000 - 6000	14'6"	15'6"	17'	18'	21'6"	19'	24'
6000 - 7000	15'	16'	17'6"	18'6"	22'	20'	24'6"
7000 - 8000	15'6"	16'6"	18'	19'	23'	20'6"	25'6"
8000 - 9000	16'	17'	18'6"	20'	24'	21'	26'6"
9000 - 10000	16'6"	17'6"	19'	20'6"	24'6"	22'	27'

## CHIMNEY

This fireplace is certified for use with 10" ICC Model RIS chimney only. Please refer to Table 1 (D-E) for the minimum and maximum chimney heights permitted with the RUMFORD 1000 fireplace.

We recommend that the minimum height be increased by approximately 1' for every 2000' elevation above sea level. Every 15°, 30° or 45° elbow also increases the minimum height by 1'. For example, if you are living 6000' above sea level, your chimney should terminate at least 15' from the top of the fireplace (12' + 3' for the 6000'). See Table 4 for more precise recommended flue heights.

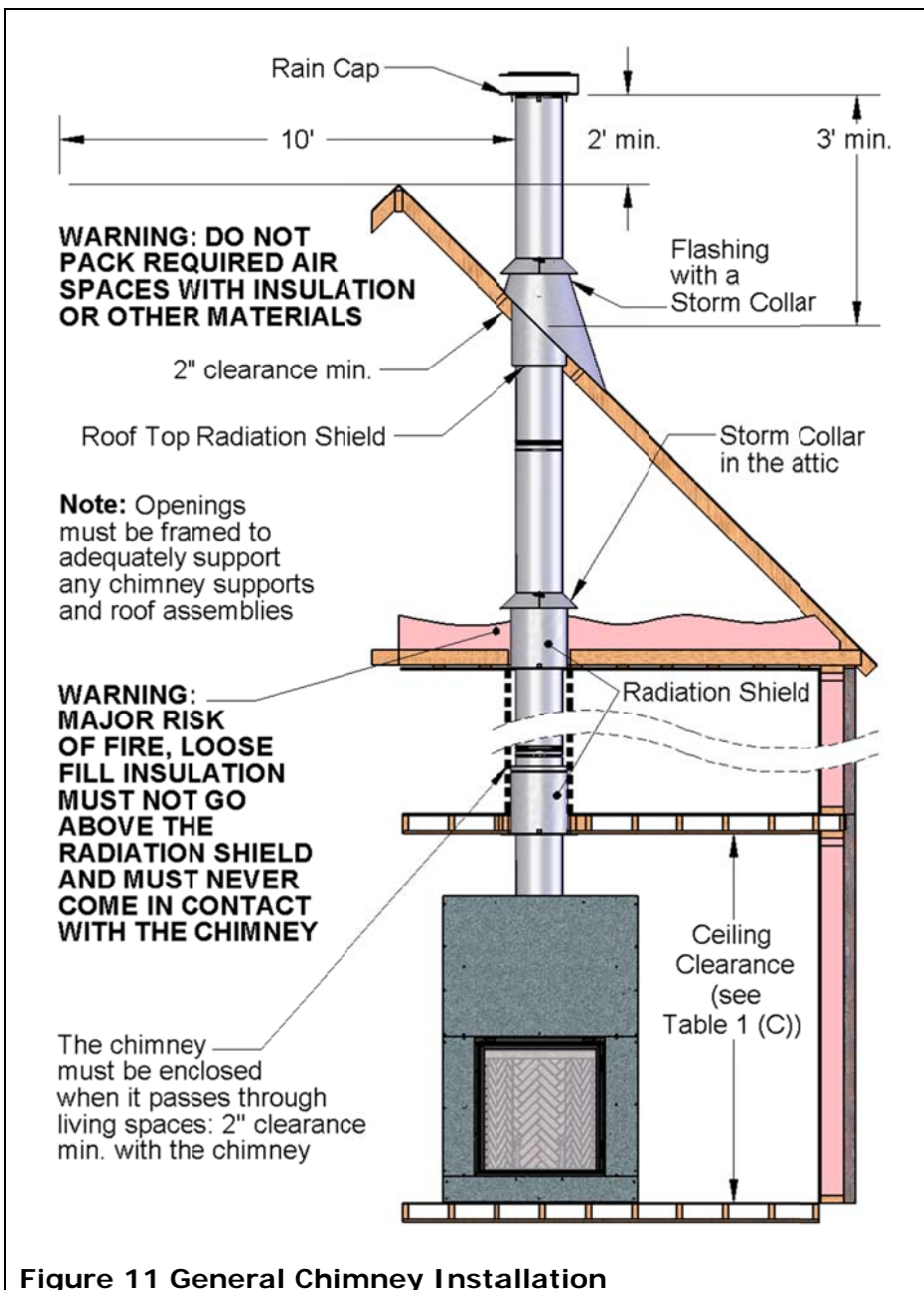

## CHIMNEY INSTALLATION

Read the RIS Chimney installation manual concerning requirements for supports, bracing, anchors, etc. It can be found online at: [www.icc-rsf.com/en/installation-instructions-model-ris-canada-and-usa](http://www.icc-rsf.com/en/installation-instructions-model-ris-canada-and-usa). Refer to Table 1 (F) for the maximum chimney height that can be supported by the top of the fireplace.

**WARNING: THE CLEARANCE BETWEEN THE CHIMNEY AND COMBUSTIBLE MATERIAL MUST BE 2" OR MORE. DO NOT FILL THIS AREA WITH INSULATION.**



1. Cut and frame the required holes in the floor(s), ceiling(s) and roof where the chimney will pass through. The rough opening in the framing is 16" square (the opening can be slightly bigger, up to 16 ½", but NEVER smaller).
2. From below, install a radiation shield in each floor through which the chimney passes. At the attic level, install a radiation shield and a storm collar as shown in Figure 11.

**WARNING: A RADIATION SHIELD MUST BE INSTALLED AT EACH FLOOR WHERE THE CHIMNEY PASSES THROUGH.**



3. Install the first chimney length on top of the flue adapter of the fireplace and secure it with the screws provided. Continue adding lengths and supports as required until the chimney penetrates the roof deck or top of the chimney chase.

The chimney must extend at least 3' above its point of contact with the roof and at least 2' higher than any wall, roof, or building within 10' of it. If the chimney is higher than 5' above the roof, it must be secured using a roof brace.

4. At the roof level, install a roof top radiation shield.
5. Put the roof flashing into place. Seal the joint between the roof and the flashing with roofing tar. For sloping roofs, place the flashing under the upper shingles and on top of the lower shingles. Secure the flashing to the roof with roofing nails or screws.

**If the chimney is enclosed to the roof:** use a vented flashing.

**If the chimney is not enclosed in the attic:** use a regular flashing.

6. Place the storm collar over the chimney and flashing. Seal it around the chimney with silicone sealer (**DO NOT use roofing tar**).
7. Fit the rain cap on the chimney. Secure it tightly in place with the screws provided.

### OFFSET CHIMNEY

An elbow may be installed directly on top of the fireplace if required. Use the 10" RIS offset charts in the RIS chimney installation manual which can also be found at: [www.icc-rsf.com/en/model-ris-offset-tables](http://www.icc-rsf.com/en/model-ris-offset-tables). Use the offset option if you need to

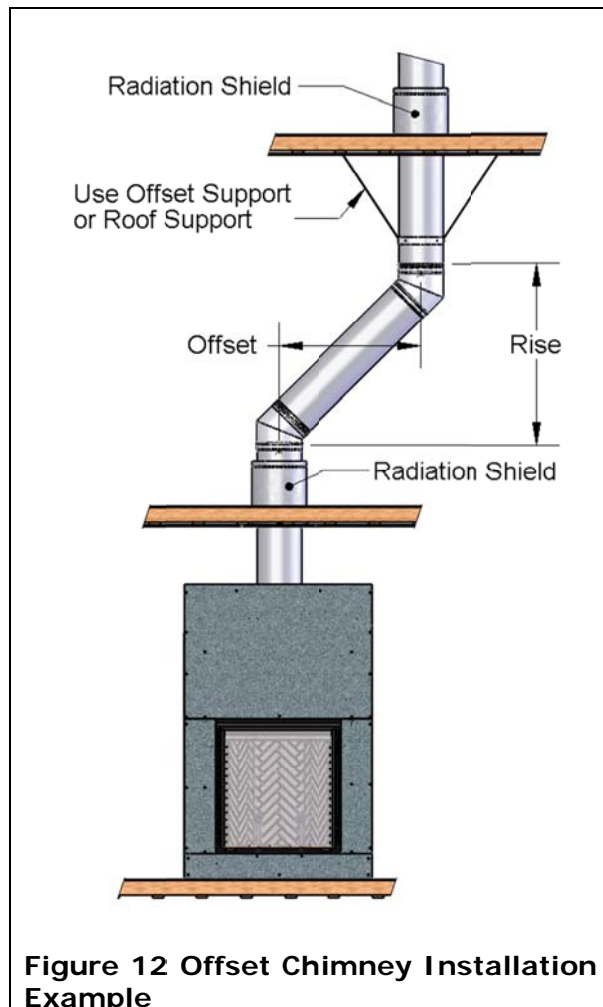

**Figure 12 Offset Chimney Installation Example**



clear a joist or pass around a cupboard. See Figure 12 and Figure 13 for example.

The maximum offset angle:

- In **USA**: 30°;
- In **Canada**: 45°.

The maximum number of elbows per system is four, resulting in two offsets and returns.

Install the fireplace and chimney as described earlier. When you require an elbow, proceed as follows:

1. Install the elbow. Turn it in the desired direction, and fasten it to the other section with 4 metal screws at the joints.
2. Install enough lengths to obtain the desired offset. Secure each joint with 4 metal screws.
3. Use another elbow to return the chimney to the vertical direction. Again fasten it to the other section with 4 metal screws at the joints.
4. Install a roof support, a wall support, or an offset support above each offset to support the weight of the chimney (elbows are not designed to support the chimney above an offset).

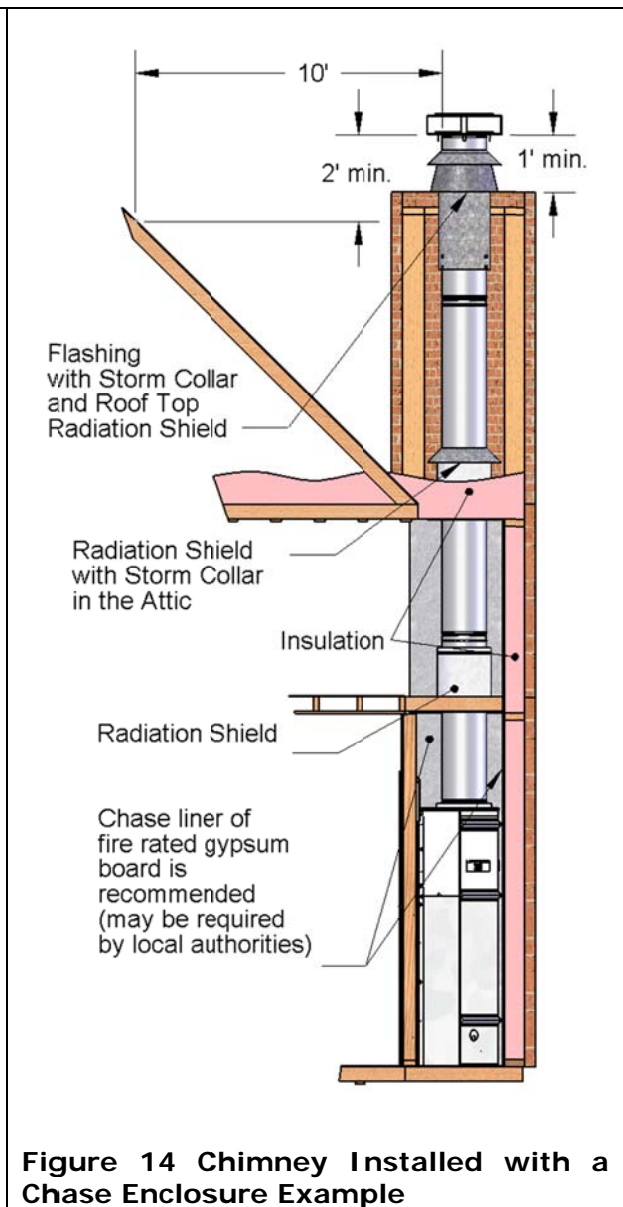
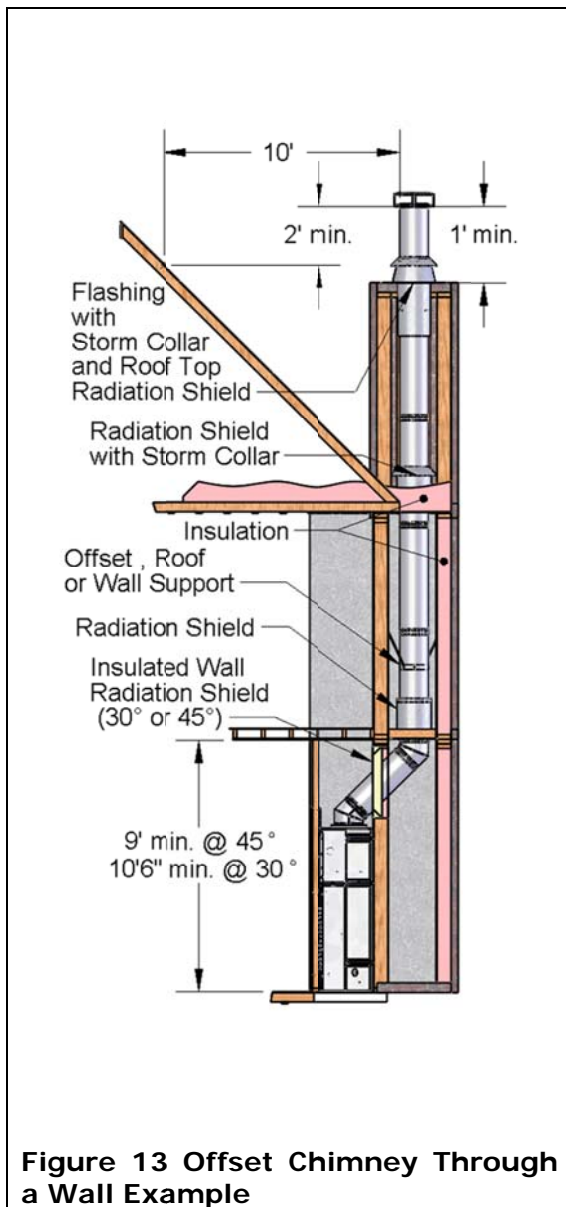

## CHASE ENCLOSURE

If the chimney runs up the outside of the house, we recommend that it be enclosed in a chase structure. The chase should be constructed in such a way that it is an extension of the home (see Figure 13 and Figure 14). It should be well insulated between the footings and the floor of the home to prevent heat loss. If the climate in your area is mild, insulate the chase at least to the first firestop. If the climate in your area is very cold, insulate the chase to the top to keep the chimney warmer, increase the draft, and reduce creosote buildup. We also recommend insulating the ceiling of the chase just as if it were in the attic space. This will prevent cold air from dropping down through the chase and into the room where the fireplace is installed (see Figure 13 and Figure 14).

Some local codes require that the walls be insulated, vapor sealed and sheathed with a fire rated gypsum board (see Figure 13 and Figure 14). We strongly recommend this procedure for all installations to prevent cold drafts from originating in the fireplace enclosure. If you follow this procedure, we recommend that you do not insulate the wall above the front of the fireplace.

**REMEMBER: CHECK LOCAL CODES CONCERNING INSTALLATION REQUIREMENTS AND RESTRICTIONS IN YOUR AREA.**



## FRAMING

The enclosure walls can be framed with any suitable materials (2"x4" or 2"x6" studs, plywood, gypsum board, etc.). Because of the high heat output potential of the RUMFORD 1000, combustible materials must NOT go closer to the fireplace than the standoffs, top, back and sides. The bottom of the fireplace can sit directly on a combustible floor.

## FIREPLACE FACING

The facing of the RUMFORD 1000 MUST be covered with at least 1/2" cement board panels such as James Hardie HardieBacker® or USG Durock® cement boards. Either product will then allow you to finish the facing of the fireplace with any non-combustible material you like.

**WARNING: DO NOT USE GYPSUM BOARDS.**



## INSTALLING THE CEMENT BOARD PANELS

**WARNING: MAKE SURE THE GUILLOTINE DOOR AND FIRESCREEN ARE BOTH CLOSED BEFORE INSTALLING THE CEMENT BOARD PANELS.**



Refer to Figure 15 for minimum area that MUST be covered by the cements boards along with recommended minimum dimensions for the various

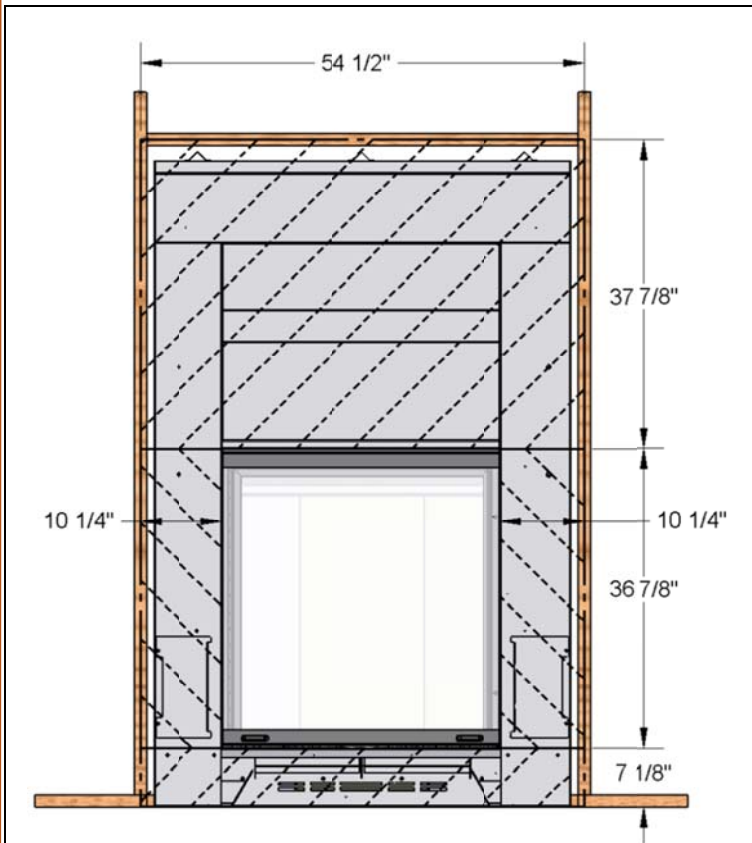

**Figure 15 Cement Board Panels Minimum Dimensions**



ceментs panels to be prepared and installed.

Make sure to use 1" wood screws and only screw where specified in Figure 16 otherwise you may damage the guillotine system or impede its operation.

Depending on your desired installation for the hearth extension, you need, or not, to install the bottom panel (see the Hearth Extension section).

**COVERING THE FIREPLACE FACING**

Facing materials must be NON-COMBUSTIBLE such as metal, brick, slate or ceramic tile. Gypsum board is NOT an acceptable facing material. The only combustible material accepted on the facing of the fireplace is for a mantel (shelf and posts).

The cement boards can be painted, textured or tiled just as you would over gypsum boards. The lintels provided with the fireplace are appropriate for thin facing materials. A wider steel lintel may be required for heavy rock. If so, contact your local sheet metal contractor for a custom steel lintel.

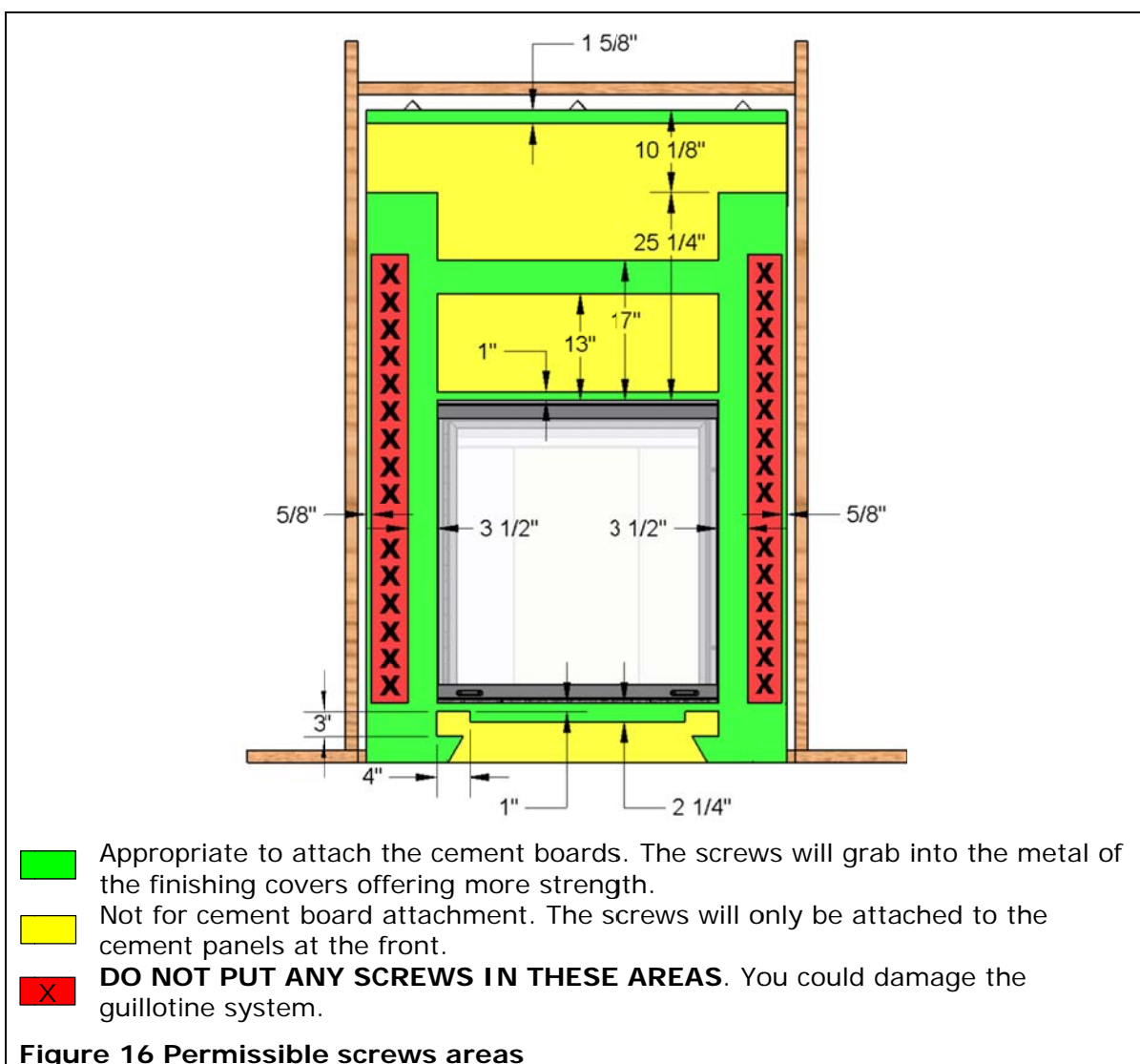

If you need to attach anything to the front of the fireplace make sure to close the guillotine door and firescreen before attempting to do so. Refer to Figure 16 to know

where you are allowed to screw. Use screws that penetrate by no more than  $\frac{3}{4}$ " the front surface of the cement boards.

Any deeper penetration of the screw tip or placing the screws anywhere else will either prevent the proper operation of the firescreen and/or the guillotine door, or eventually cause difficulty dismantling the guillotine system.

**CAUTION: IF ABSOLUTELY NECESSARY, YOU CAN SCREW INTO THE CEMENT FACING ELSEWHERE AS LONG AS THE SCREW TIP DOES NOT COMPLETELY PENETRATE THE  $\frac{1}{2}$ " CEMENT BOARD PANELS.**



Confirm that you have not impeded the normal operation of the firescreen and the guillotine door by moving them slowly.

## HEARTH EXTENSION

The area immediately in front of the fireplace must be protected. Refer to Table 1 (G-H) for the depth and width that the hearth protection should extend beyond the front and both sides of the fireplace opening (see Figure 2). Refer to Figure 17 for various alternatives of hearth extension installation.

If the RUMFORD 1000 is installed on a non-combustible floor (a non-combustible floor surface with a non-combustible floor structure), the floor protection is not required.

The floor protection required includes:

### 1. Spark Guard

The spark guard provided (J) must be installed  $2\frac{1}{2}$ " under the fireplace base and  $2\frac{1}{2}$ " under the hearth extension, centered on the fireplace opening. It is dimensioned so that it will also cover the entire floor area under the metal front step of the fireplace. This guard prevents sparks from lodging in this area and starting a fire.

If you are installing the fireplace on a combustible raised platform, you will need a second spark guard (not provided) with the same dimensions as the one we have provided. One spark guard will be installed below the hearth extension and the raised platform. The second spark guard will be installed below the fireplace. Both spark guards must be centered on the fireplace.

### 2. Thermal protection of a minimum R-Value of 0.52

Adequate thermal protection must be provided for the combustible floor structure of the hearth extension. The thermal protection must have the same minimum dimensions as the hearth extension (see Table 1 (G-H)) and it must be installed under the non-combustible flooring and above the spark guard.

See Table 5 for various possibilities. If you want to use alternative materials, you simply need to add the R-Values of each material considered for the hearth extension. The R-Values are linked to the thickness of the material, if the material considered is twice the thickness in our table, just multiply by two the R-Value. For example:

- You could use 1" HardieBacker and  $\frac{1}{4}$ " ceramic tile:  $(2 \times 0.26) + 0.02 = 0.54$  R-Value
- You could use 5" of limestone:  $5 \times 0.108 = 0.54$  R-Value
- You could use 1" WonderBoard and  $4\frac{1}{2}$ " of Sandstone:  $(2 \times 0.15) + (4.5 \times 0.05) = 0.525$  R-Value

If the fireplace is raised by a minimum of 6", the thermal protection is NOT required.

A raised hearth constructed of non-combustible cement board and metal studs will provide adequate thermal protection.

**Table 5 Thermal Protection Alternatives for the Hearth Extension**

<b>Material</b>	<b>Nominal Thickness</b>	<b>R-Value for nominal thickness</b>
Cement board: Durock or HardieBacker <sup>2</sup>	½"	0.26
Cement board: Wonderboard <sup>3</sup>	½"	0.15
USG Micore 160 <sup>2</sup>	½"	1.27
USG Micore 300 <sup>2</sup>	½"	1.03
Common Brick <sup>4</sup>	2 ¾"	0.475
Ceramic Tile	¼"	0.02
Granite <sup>5</sup>	1"	0.038
Limestone <sup>5</sup>	1"	0.108
Marble <sup>5</sup>	1"	0.049
Sandstone <sup>5</sup>	1"	0.05
Quartzite <sup>5</sup>	1"	0.027

Whether the fireplace is installed on a non-combustible floor or a combustible floor, non-combustible flooring material such as brick, tile, stone, or slate must be used as finishing material over the hearth extension area.

The non-combustible flooring must have the same minimum dimensions as the hearth extension (see Table 1 (G-H)) and must be installed on top of an adequate thermal protection.

<sup>2</sup> From Manufacturers technical data

<sup>3</sup> Hearth & Home Magazine, July 2008, page 70.

<sup>4</sup> From the ColoradoENERGY.org

<sup>5</sup> From the Marble Institute of America

**Regular Hearth Extension**

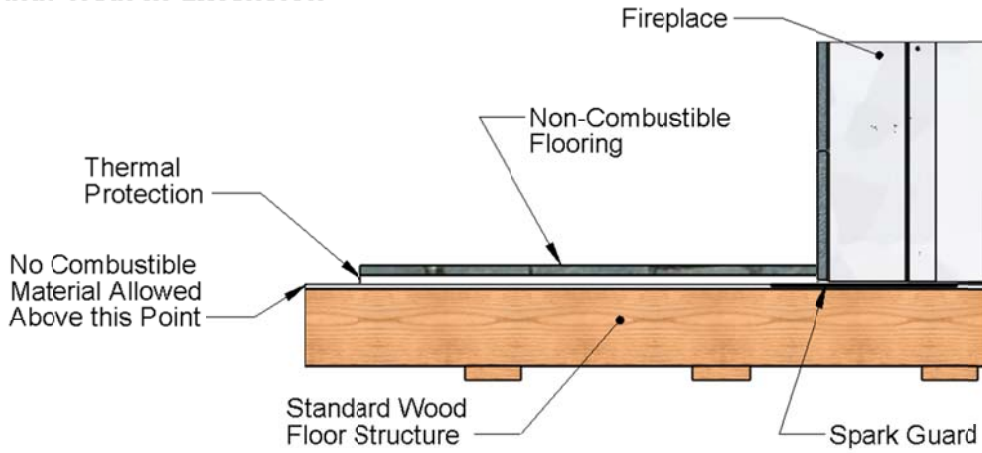

**Raised Hearth Extension**

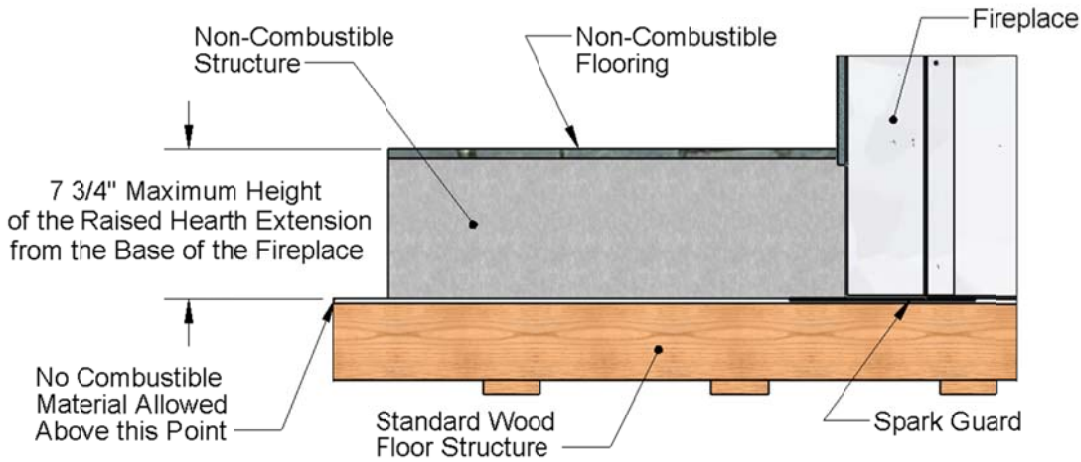

**Raised Fireplace Hearth Extension**

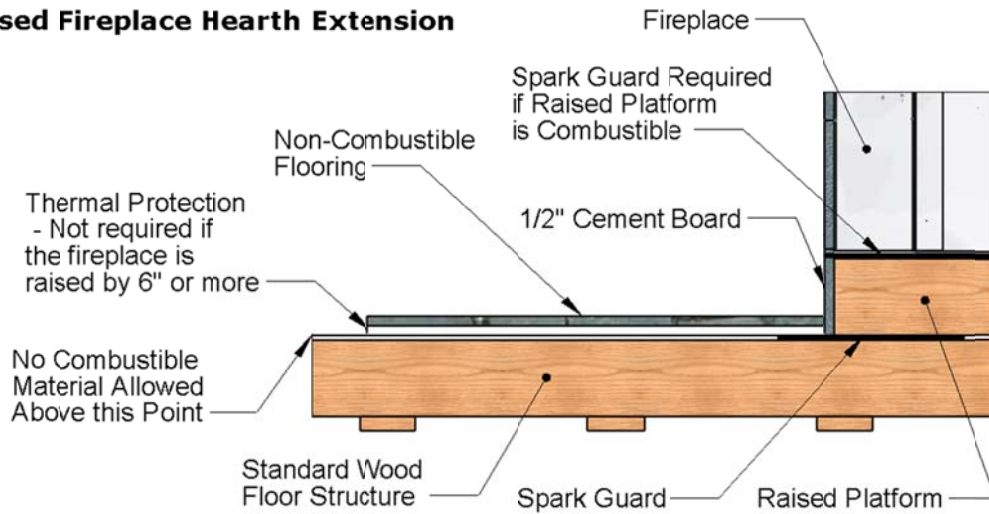

**Figure 17** Hearth Extension Examples

## MANTEL

Masonry and other non-combustible mantels (shelf and posts) can be placed anywhere around the fireplace opening.

For combustible mantels (shelf and posts), please see Table 1 (J-K-L-M) for the maximum depth of the mantel shelf and posts and their installation clearance requirements. See Figure 2 for an example.

The only combustible material accepted on the facing of the fireplace is for a mantel (shelf and posts).

If you need to attach the mantel to the front of the fireplace refer to page 23 to know where screws are permitted on the front of the fireplace facing.

## FIREBOX LINING INSTALLATION

The firebox lining of the RUMFORD 1000 fireplace is packaged separately from the fireplace. You must make sure that all is properly installed inside the firebox before making your first fire. This is easily accomplished with the following instructions.

Before you begin the installation, please take note:

- Make sure the bottom of firebox is cleaned before starting the installation.
- Even though all components can be easily installed by one person, you might find the installation easier with a partner handing you one component at the time.
- Three different types of components are used: semi-rigid and rigid insulation panels and, vermiculite panels or refractory bricks depending on the option selected.
- Rigid insulation panels are fragile. Please handle them carefully during the installation. Nevertheless, if an insulation panel is cracked you can still install it as long as you make sure to install all its pieces correctly.
- The firebox lining has been designed specifically for the RUMFORD 1000 and no modifications are required to ensure a proper fit.

### VERMICULITE PANELS (EO-VP1000)

The following steps are for the installation of the vermiculite panels. To remove any of the panels, just follow the installation procedure in the reverse sequence. Refer to Figure 18, Figure 19 and Figure 20 to adequately identify each component at each step of the installation.

Vermiculite panels with varying densities are used. Some individual panels, which are not to be meant to be bumped by wood logs, are more fragile than others. Please handle them carefully during the installation.

Please refer to Figure 18 while following the installation procedure below:

1. First, find the throat refractory brick (1) and the three semi-rigid insulation sides and back panels (2). The rigid bottom insulation panels will be installed at the end.
2. Take the throat refractory brick (1) and hold the wider part of the throat refractory brick with your two hands, flat face towards you. Place yourself down on your knees in front of the fireplace opening. Tilt and slide the throat refractory brick inside the firebox along the flue divider at the top of firebox. Slowly slide the throat refractory brick up so you can lay it on the  $\frac{5}{8}$ " bend. Slide it horizontally to the right side to ease the installation of the upper left side insulation (2a). Let the throat refractory brick tilt towards the flue divider. It will stay in place by itself.

3. Slide the left side insulation (2a) on the left side of firebox all the way to the top. You may need to tilt the throat refractory brick (1) towards you to help the insulation reach the top.
4. Slide the right side insulation (2b) on the right side of firebox all the way up. You may need to tilt the throat refractory brick (1) towards you to help the insulation to reach the top.
5. Slide the back insulation (2c), along the back of firebox, between the two side insulation panels (2a and b).
6. Place the two refractory support brackets against the back insulation panel so that they are centered and 8" apart as shown in Figure 18. They are absolutely necessary to provide a sturdy backing for both the lower back refractory brick and the middle back refractory brick.

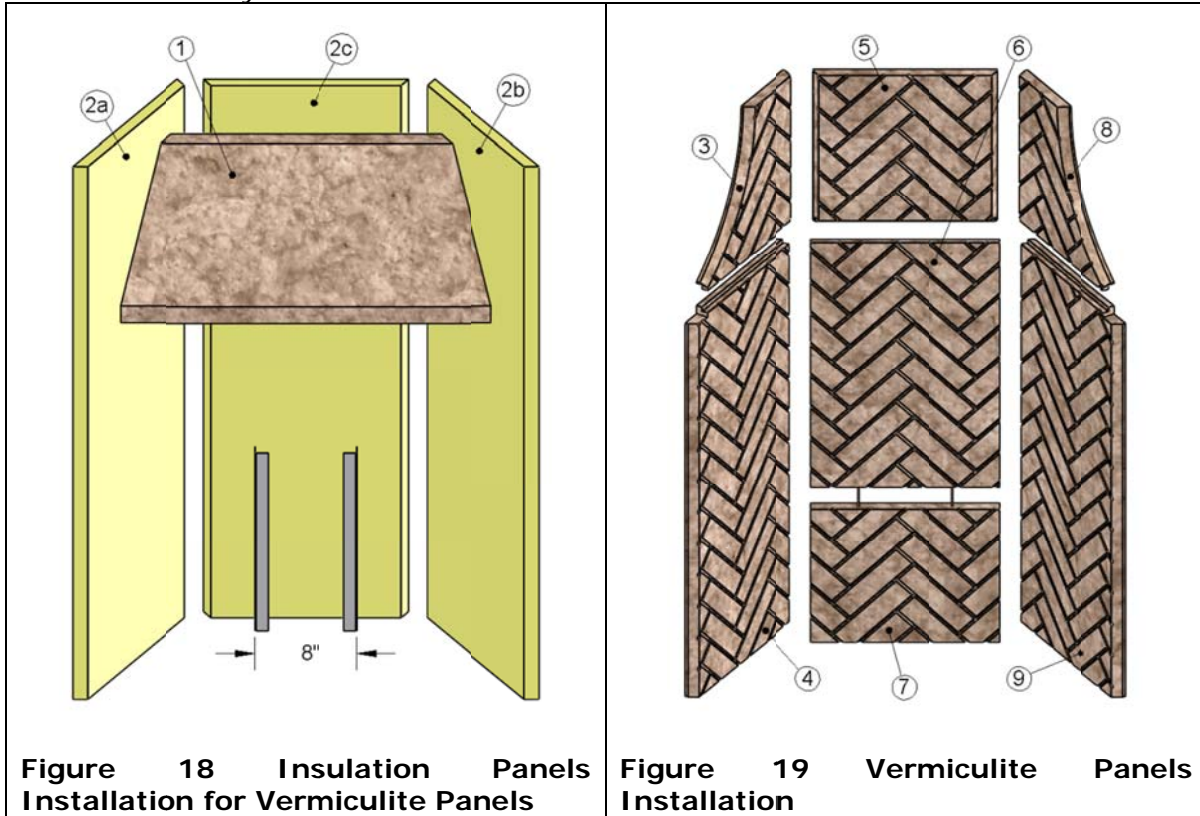

**Figure 18 Insulation Panels Installation for Vermiculite Panels**

**Figure 19 Vermiculite Panels Installation**

Please refer to Figure 19 while continuing with the installation procedure below:

7. Have the seven refractory bricks (four for the sides and three for the back, parts 3 through 9) handy. The rest will be installed at the end.
8. Tilt the throat refractory brick (1) toward the front of the fireplace and slide the upper left side refractory brick (3) on the left side of firebox all the way to the top. Let the throat refractory brick (1) lay down to the upper left side refractory brick (3). Hold it with one hand.
9. Install the lower left side refractory brick (4), trimmed part up, underneath the upper left side refractory brick (3). They will stay in place by themselves.
10. In preparation for its installation, insert the two copper wires into the holes at the top of the lower back refractory brick (7). They will maintain the alignment between the lower back refractory brick and the middle back refractory brick. Take the time to look at the corresponding holes in the middle back refractory brick (6) into which the copper wires will need to be inserted.



11. Slide the upper back refractory brick (5), with the center of the herringbone pattern pointing upward, along the back of firebox, next to the upper left side refractory brick (3). Hold it with one hand as high as it will go.
12. While holding the upper back refractory brick (5), install the middle back refractory brick (6), with the center of the herringbone pattern pointing upward, underneath the upper back refractory brick (5). Now move your hand to hold the middle back refractory brick (6).
13. While holding the middle back refractory brick (6), install the lower back refractory brick (7), inserting the coppers wires into the corresponding holes in the middle back refractory brick (6). The three back refractory bricks will stay in place by themselves.
14. Tilt again the throat refractory brick (1) towards you and slide the upper right side refractory brick (8) on the right side of firebox all the way to the top. Let the throat refractory brick (1) lay down. Hold it with one hand.
15. Install the lower right side refractory brick (9), trimmed part up, underneath the upper right side refractory brick (8).

Please refer to Figure 20 while to continue with the installation procedure below:

16. To install the next refractory brick, make sure the door is up at its maximum. Hold the top refractory brick (10) with the longitudinal notch on the top, facing the fireplace. From inside the fireplace, slide the brick along front facing inside the firebox, up to the top. Rotate the brick 90 degree to the back. The notch will fit to the front angle. Hold it with one hand.
17. While holding the top refractory brick (10), install the front left (11) and right (12) refractory bricks on each side, the top notch towards the fireplace.
18. Clean the bottom of firebox and install both back bottom insulation panels (13) and then both front bottom insulation panels (14). Move all four parts as close to the front as possible.
19. Install the ash step (15), tight to the front.
20. Install all the bottom refractory bricks: the central refractory brick (17) between the two side refractory bricks (16).
21. Complete the installation with the three parts of the hearth threshold (18, 19 and 20). The left part (18) has the shortest groove compared to the right part (20). The beveled faces go towards the front of the fireplace. Once installed, they will extend  $\frac{1}{2}$ " inch beyond the front of the metal front step to cover the bottom cement board panel. You can put one drop of high temperature silicone under each part of the hearth threshold to keep them in place.

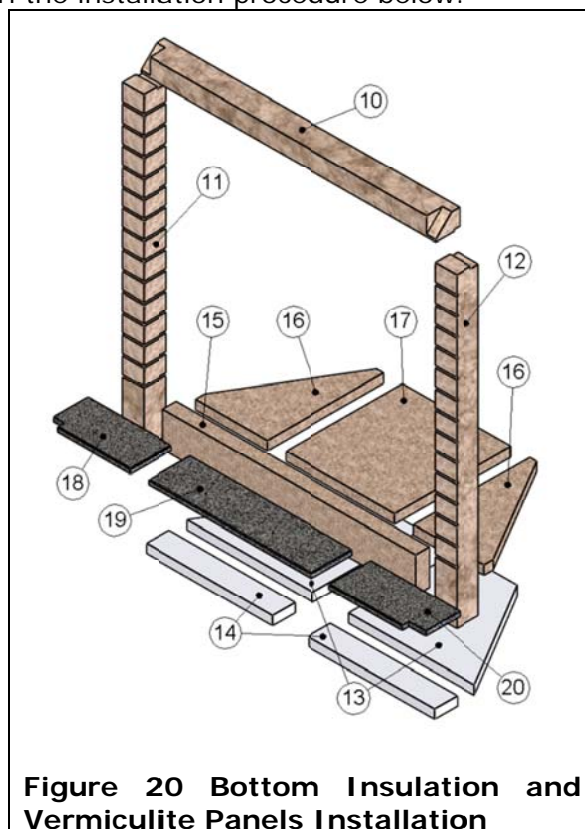

**Figure 20 Bottom Insulation and Vermiculite Panels Installation**

### **CEMENT REFRACTORY BRICKS (EO-RB1000)**

The following steps are for the installation of the cement refractory bricks. To remove any of the refractory bricks, just follow the installation procedure in the reverse sequence. Refer to Figure 21 through Figure 28 to adequately identify each component at each step of the installation.



Please refer to Figure 21 while following the installation procedure below:

1. First, find the throat refractory brick (1) and the three semi-rigid insulation sides (3) and back panels (2). The rigid bottom insulation panels will be installed at the end.
2. Take the throat refractory brick (1) and hold the wider part of the throat refractory brick with your two hands, flat face towards you. Place yourself down on your knees in front of the fireplace opening. Tilt and slide the throat refractory brick inside the firebox along the flue divider at the top of firebox. Slowly slide the throat refractory brick up so you can lay it on the  $\frac{5}{8}$ " bend. Slide it horizontally to the right side to ease the installation of the upper left side insulation (3a). Let the throat refractory brick tilt towards the flue divider. It will stay in place by itself.
3. Slide the back insulation (2), along the back of firebox, it should be centered.
4. Slide the left side insulation (3a) on the left side of firebox all the way to the top. You may need to tilt the throat refractory brick (1) towards you to help the insulation reach the top. It should rest snug against the back insulation panel (2).

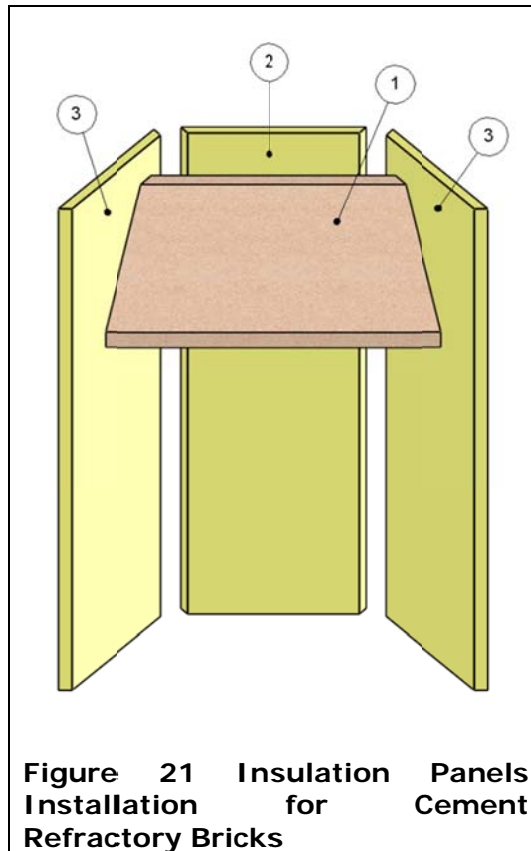
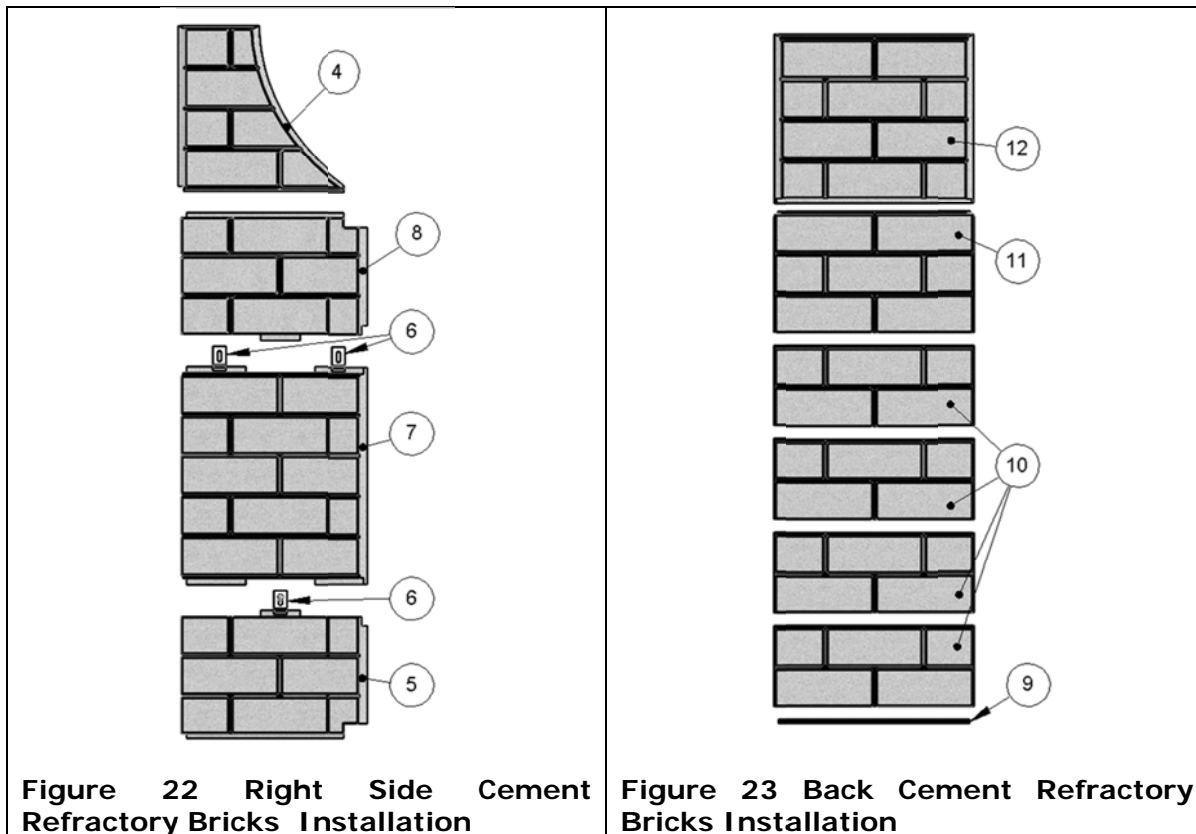

**Figure 21 Insulation Panels for Cement Refractory Bricks**

5. Slide the throat refractory brick (1) towards the left, against the insulation. Slide the right side insulation (3b) on the right side of firebox all the way up. You may need to tilt the throat refractory brick (1) towards you to help the insulation to reach the top. It should rest snug against the back insulation panel.

Please refer to Figure 22 and Figure 23 while continuing with the installation procedure below:

6. Have the four bricks for the right side and the six bricks for the back along with three brick supports and three back brick spacers (parts 4 through 12) handy. Be aware that you have two bricks (5), two bricks (7), two bricks (8) and six brick supports (6) in total. They are also used for the left side.
7. Place the three back brick spacers (9) on the bottom of the firebox, centered just in front of the back insulation panel (2). Install one small back brick (10) over the spacers. Make sure to center the brick in the firebox and to orient the brick pattern correctly, refer to Figure 23.
8. Install the lower side brick (5) on the right side, at about  $\frac{1}{8}$ " from the back brick. Check to confirm that the brick pattern is aligning between the side and the back. If necessary remove one of the back brick spacers (9) to lower the back brick and align the brick pattern.
9. Take one brick support (6) and place it as shown in Figure 24a), the side with the oblong hole resting against the insulation (3) and the rest of the support against the brick tab, centered on the brick tab.
10. With a utility knife, cut through the insulation on both sides of the support. Do not cut across the top of the support.



**Figure 22 Right Side Cement Refractory Bricks Installation**

**Figure 23 Back Cement Refractory Bricks Installation**

11. Remove the support and the lower side brick (5). Cut the insulation across at the bottom of the two vertical cuts. Carefully pull up the insulation without tearing it.
12. Replace the lower side brick (5) on the right side along with the brick support (6) under the insulation. The part with the oblong hole should rest against the firebox wall while the other part of the support rests against the brick.
13. Take one of the self-tapping screws provided with the cement bricks and position it at the top of the oblong hole.
14. Using a hand drill, screw the screw into the firebox wall. Make sure not to tighten the screw against the brick support. It should be free to move up and down as shown in Figure 24b).
 

If the brick support is not able to freely move, it will constrict the refractory brick in its place while the fire is burning which may cause the brick to crack. The brick support just needs to prevent the refractory brick from tilting forward, nothing else.
15. Leave the brick support resting against the lower brick and carefully close the insulation on top of the brick support.
 

If and when you need to remove the refractory bricks, the brick support does not need to be removed, just lift it enough to disengage the brick. Always make sure to close the insulation back over the brick support, once the brick is back in place.
16. Place the middle lower refractory brick (7) on top of the lower refractory brick (5). Be careful to insert the tabs of each brick into the other brick.
17. Two brick supports (6) need to be installed as shown in Figure 24c). Repeat steps 10 to 15 for both supports.
18. Install the other small back refractory bricks (10). Make sure to align the brick pattern with the first one installed. They will hold their place with the help of the right side refractory bricks.

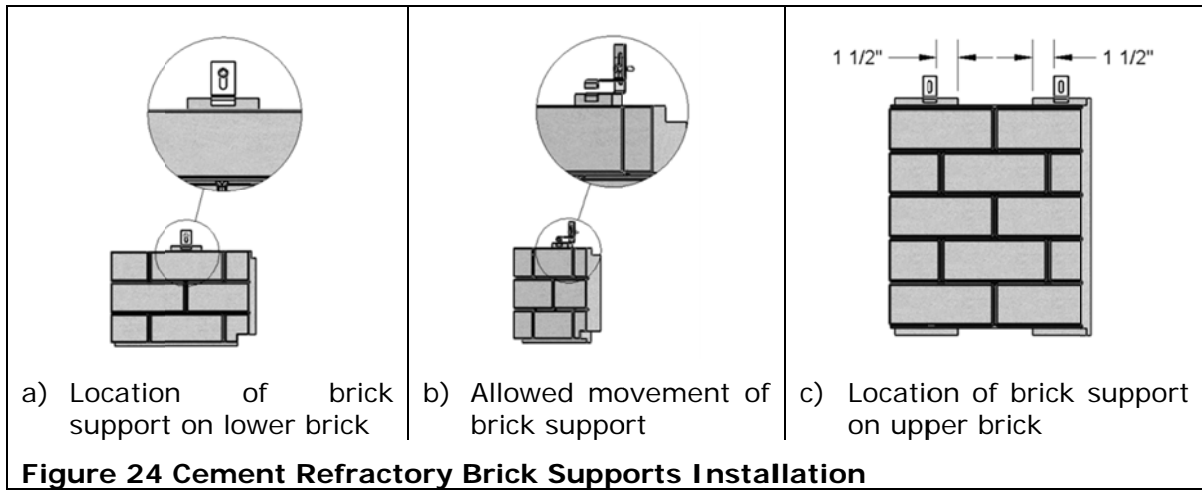

19. Install the back middle refractory brick (11). The end with a step goes topside and will mate with the next brick. Hold it with one hand.
20. Next, install the upper back refractory brick (12). Again make sure to align the brick pattern. Hold it with one hand.
21. Make sure you have both the upper (4) and middle upper (8) right refractory bricks very close. With your elbow keeping the back bricks in place, use your hand to tilt the throat refractory brick (1) toward the front of the fireplace and slide the upper right side refractory brick (4) on the right side of firebox all the way to the top. Let the throat refractory brick (1) lay down on the upper right side refractory brick (4). Move your hand to hold it. The back bricks will now hold their place.
22. Take the middle upper (8) right refractory brick. On one end, there is one step for mating with the upper brick (4). At the other end, there is one tab that will insert into the groove of the middle lower brick (7). Start by mating the middle upper brick (8) with the upper brick (4), while pushing the two bricks upwards; tilt the throat refractory brick (1) towards the front to allow the side bricks to slide up. Insert the tab of the middle upper brick into the groove of the middle lower brick. The side bricks will now hold their place.
23. Slide the throat refractory brick as far right as it will go, you may have to tilt it forward to slide through the upper refractory brick (4) round cut. Let it rest against the upper right refractory brick (4).

While referring to Figure 25, install in sequence the lower left side brick (8), the brick support (6), the middle lower side brick (7), the two brick supports (6), the middle upper side brick (5) and finally the upper left brick (13), repeating steps 9 to 17, 21 and 22.

24. Tilt the throat refractory brick (1) once more and move it towards the left to engage it over the curved surface of the left upper refractory brick. It should be centered.

Please refer to Figure 26, Figure 27 and Figure 28 to continue with the installation procedure below:

25. Find the two front refractory bricks (19) and place one on your left and one on your right.
26. To install the next refractory bricks, make sure the door is up at its maximum. Hold the top refractory brick (18)

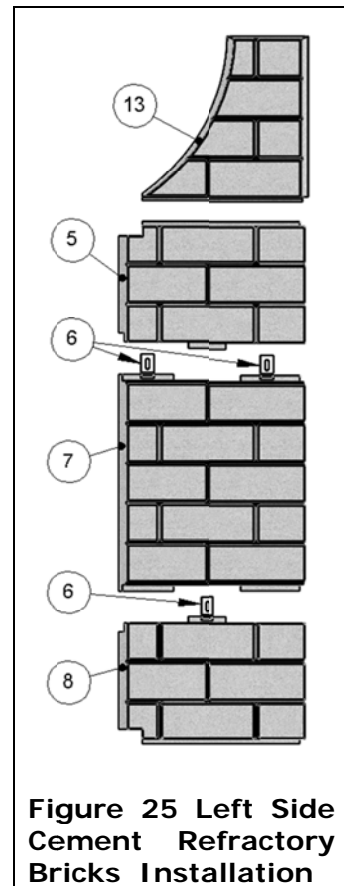

oriented as shown on the left side of Figure 26. From inside the fireplace, slide the brick along front facing inside the firebox, up to the top. Rotate the brick 90 degree to the back as shown in Figure 26. The notch will fit to the front angle. Hold it with one hand.

This side facing out of the fireplace

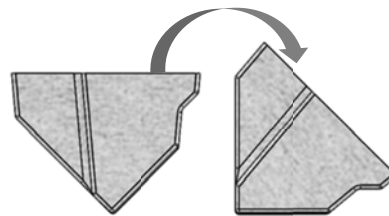

This side facing in the fireplace

**Figure 26 Side View of the top refractory brick (18)**

27. While holding the top refractory brick (18), install the front left (19) and right (19) refractory bricks on each side. The unfinished surfaces must be facing out towards the side of the fireplace.
28. Let the top refractory brick (18) rest against the two front refractory bricks (19).
29. Clean the bottom of firebox and install both back bottom insulation panels (14) and then both front bottom insulation panels (15). Move all four parts as close to the front as possible.
30. Next install the second layer of insulation by installing the side top insulation (17) on either side with the central top insulation (16) in the middle. Again move all parts close together and as close to the front as possible.
31. Install the ash step (20), tight to the front.
32. Install all the bottom refractory bricks: the central refractory brick (22) between the two sides refractory bricks (21 and 23).
33. Complete the installation with the three parts of the hearth threshold (24, 25 and 26). The left part (26) has the shortest groove compared to the right part (24). The beveled faces go towards the front of the fireplace. Once installed, they will extend ½" inch beyond the front of the metal front step to cover the bottom cement board panel. You can put one drop of high temperature silicone under each part of the hearth threshold to keep them in place.

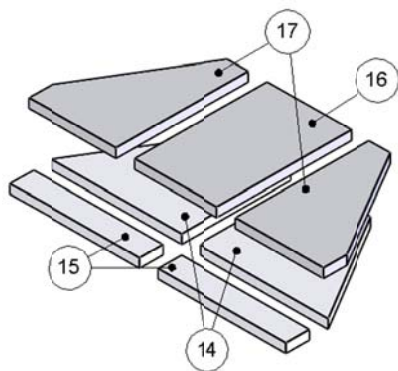

**Figure 27 Bottom Insulation for Cement Refractory Bricks**

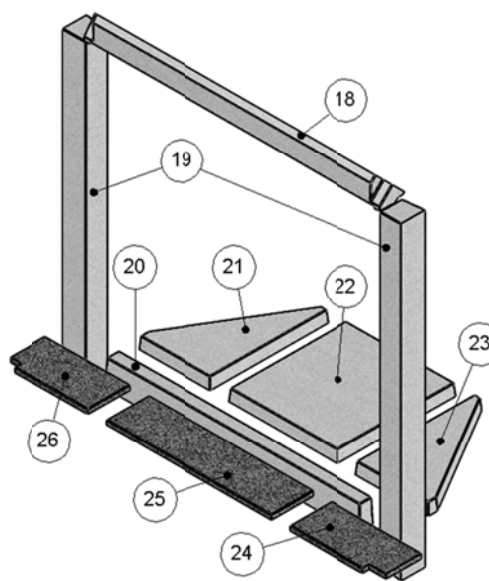

**Figure 28 Surround and Bottom Cement Refractory Bricks**

## OPERATION

### OUTSIDE AIR CONTROL

The RUMFORD 1000 is designed to use outside air for combustion. The control for the outside air is located on the left side beyond the door rail, approximately half way up (see Figure 29).

Fully open the door and the firescreen to access the external air control.

**To minimize the risk of injuries or burns, do not touch the external air control and the surrounding parts with your bare hands while the fireplace is hot. They may be hot enough to burn.**

When the round portion of the external air control is down, the outside air damper is open. When it is up, the outside air damper is closed. Use your door handle or a gloved hand to adjust the air control when the fireplace is hot.

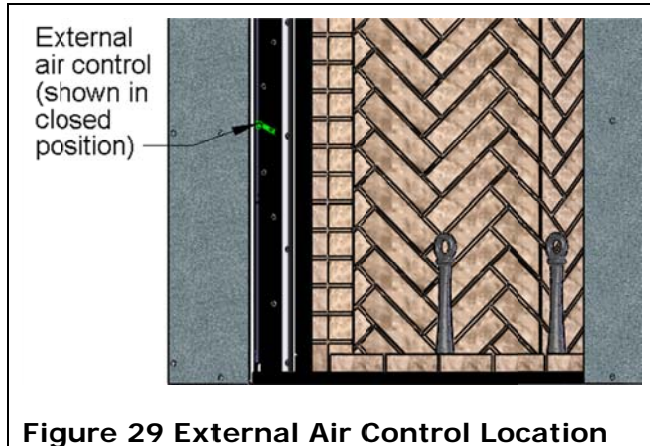

Do not use force to move the control, it should turn freely about its pivot point. A spring keeps it open or closed. It will not change position by itself.

Even if the fireplace can be operated with the outside air damper closed, we recommend always using outside air for combustion when burning the fireplace with the door closed. Outside air is generally colder and denser it will help keep your glass cleaner. In some cases this fresh air will also help compensate for negative pressure problems within the house; however it will not prevent the fireplace from smoking in a severely depressurized house.

We also recommend using outside air for combustion when burning the fireplace with the firescreen closed. It will help reduce the depressurization of the house caused by burning the fireplace with the firescreen.

This control should be closed when the fireplace isn't burning to prevent cold air infiltration. It is sealed with a gasket.

### LIGHTING THE RUMFORD 1000

To light a fire in your RUMFORD 1000, place a couple of pieces of paper under and between the andirons. Then add a generous layer of kindling staked vertically over the paper. Finally, stack 2-3 small-medium size logs over the kindling so that they are standing upright, light the fire and close the firescreen. After the fire is established, you can add more wood and close the door or the firescreen on your preference. Either the door or the firescreen should always be closed when the fire is burning. To minimize the emissions do not close the door until the fire is burning briskly.

Never use flammable liquids.

**WARNING: USE ONLY THE RENAISSANCE ANDIRONS PROVIDED WITH THE FIREPLACE**



### CONTROLLING YOUR FIRE

The RUMFORD 1000 fireplace is designed to provide warm radiant heat. Although it does not come with a draft control, you will find that you can control the intensity of the fire



and the quantity of flames quite well by varying the size and placement of the logs, and by burning it with either the door or the firescreen closed.

Since the burn rate is the same when the fireplace is burned either with the door closed or the firescreen closed, choosing between the two burning modes will depend on the outside temperature and your personal preference.

The RUMFORD 1000 is more efficient when burned with the door closed. Although more radiant heat will enter the room with the door open, heat from the home is being lost up the chimney. Feel free to burn your fireplace with either the screen or door closed, but the door should always be closed when no fire is burning to prevent cold air infiltration into the home.

For a cooler fire, load 3 to 4 small logs (3" diameter) either lying down on the andirons or standing up in a tipi-style and burn your fireplace with the firescreen closed.

For a warmer fire, load 3 to 4 medium logs (5" diameter) or 2 to 3 large logs (6" diameter) either lying down on the andirons or standing up in a tipi-style and burn your fireplace with the door closed.

Even though the firebox is quite big, you will soon discover that it is unnecessary to load a lot of wood to get magnificent flames. Be careful not to overload your fireplace, you will risk overfiring your fireplace and the room in which the fireplace is located. You will get greater satisfaction looking at a couple of small logs burning.



---

**WARNING: OVER FIRING THE RENAISSANCE RUMFORD WILL CAUSE DURABILITY PROBLEMS.<sup>6</sup>**

**THE RENAISSANCE IS CAPABLE OF BURNING CLEANLY PRIMARILY BECAUSE IT HAS BEEN ENGINEERED TO BURN VERY HOT, VERY QUICKLY. THIS RESULTS IN A BEAUTIFUL, CLEAN FIRE BUT CAN CAUSE DURABILITY PROBLEMS IF THE UNIT IS REGULARLY OVERLOADED AND/OR OPERATED CONTINUOUSLY WITH LARGE WOOD LOADS. THE RENAISSANCE IS PRIMARILY A DECORATIVE APPLIANCE AND ACCORDINGLY LESS EFFICIENT THAN A WOOD BURNING STOVE SO THERE IS NO BENEFIT TO BURNING LARGER WOOD LOADS.**

**THE FOLLOWING GUIDELINES WILL ENSURE YOUR FIREPLACE BURNS BEAUTIFULLY WHILE MAINTAINING ITS DURABILITY:**

**APPROXIMATE MAXIMUM LOG SIZE: 20" LONG, 6" IN DIAMETER.**

**APPROXIMATE MAXIMUM LOAD: NO MORE THAN 3 LOGS AS SPECIFIED ABOVE.**

**THIS WOOD LOAD IS MORE THAN SUFFICIENT TO FILL THE FIREBOX COMPLETELY WITH FLAMES AND PROVIDE A LARGE AMOUNT OF RADIANT HEAT.**

**THE RENAISSANCE RUMFORD WILL BURN WITH LARGE HIGH FLAMES REGARDLESS OF HOW THE WOOD IS PLACED IN THE UNIT. STACKING THE WOOD TIPI-STYLE AGAINST THE BACK OF THE FIREPLACE IS ACCEPTABLE BUT CAN COSMETICALLY DAMAGE THE FIREBOX REFRACTORY BRICKS IF YOU'RE NOT CAREFUL PLACING THE LOGS.**

**IF ANY OF THE FOLLOWING SIGNS APPEAR IN YOUR FIREPLACE THEN YOU ARE OVER FIRING:**

- **THE VERMICULITE PANELS HAVE CHANGED COLOR**
- **THE DOOR CHANNEL IS WARPED**
- **THE SMOKE DIVERTER IS WARPED**

---

<sup>6</sup> This is similar to operating a car at full throttle – it's ok occasionally but the car will wear out much more quickly if you do it on a regular basis.



## REFUELING

Fuel wood can be of any species but the fireplace will not burn cleanly or efficiently unless the wood is well seasoned. Keep your firewood under cover.

**The door should be opened slowly to keep smoke from spilling into your room. If you have a problem with smoke spillage, check to see that all kitchen and bathroom fans have been shut off. They can cause negative pressure in the house which pulls smoke out of the fireplace.**

## GUILLOTINE DOOR

The RUMFORD 1000 is equipped with a counterweighted guillotine door. Normal operation of the door should always be in a vertical motion. It can also be opened on a hinge to allow for cleaning of the glass. Please refer to the "Maintenance" section for more information on how to open the door on its hinge.

To open or close the guillotine door simply insert the handle in the door handle eye (see Figure 30) and either pull up or down. It is fully counterweighted. You can stop the door at any level and it will stay in that position until you move it again.

The handle is equipped with a leather strap to allow you to hang the handle with your fireplace's tools when you are not using it. By doing this, you will always have the fireplace handle close by.

**To minimize the risk of injuries or burns, do not touch any of the door parts with your bare hands while the fireplace is hot because they may be hot enough to burn.**

The door has a stainless steel cushion-type gasket at the bottom to ensure a good seal when it is closed. The gasket is soft enough to compensate for some dirt or ashes that may be under the door. Nevertheless, always make sure to remove anything that could prevent the door from sealing against the hearth threshold and that could damage the gasket over time.

## GUILLOTINE FIRESCREEN

The RUMFORD 1000 is equipped with a counterweighted guillotine firescreen. To operate the firescreen, simply lift on either or both of the handles. Thanks to the counterweight, it will stop at any point.

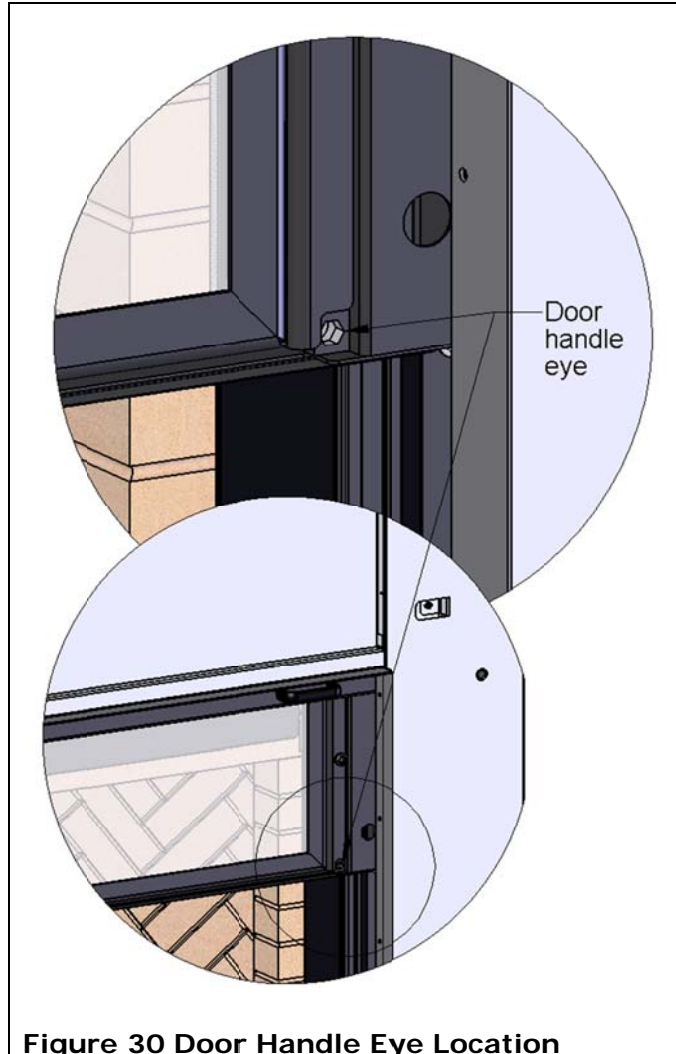

**Figure 30 Door Handle Eye Location**

## MAINTENANCE

### GENERAL CLEANING

The high heat paint can be cleaned with a soft damp cloth. Use a mild detergent and water. Do not use abrasive cleaners.

### PAINT

You can touch up the face of the RUMFORD 1000 with *Stove Bright* Metallic Black high temperature paint which is available at most fireplaces dealers. Follow the directions outlined on the spray can. **DO NOT** attempt to paint the fireplace while it is still warm. Keep the spray can away from any source of heat or open flame. Ensure that there is adequate ventilation in the room from the time you start painting until the paint is dry. *Stove Bright* is available in a wide range of colors if you want to change the color of your fireplace.

We recommend that you take the time to protect or remove any items that you do not want to paint such as: the door glass, the fireplace surroundings, etc. The glass can be removed from the door but you will have to replace the door and glass gaskets.

### GLASS CLEANING

Depending on how you burn your RUMFORD 1000, temperatures may not always be hot enough to keep the glass perfectly clean. A good hot fire once a week usually cleans off most of the deposits that have accumulated. Remember: the drier the wood and the hotter the fire, the cleaner the glass. A word of caution: although heat will not break the glass, impact can. Be careful not to hit the glass.



**WARNING: NEVER CLEAN THE GLASS WITH AN ABRASIVE CLEANER. USE ONLY A CLEANER RECOMMENDED BY YOUR DEALER. NEVER CLEAN THE GLASS WHILE IT IS HOT, A SERIOUS BURN CAN RESULT. THERE ARE A NUMBER OF EXCELLENT WOOD STOVE GLASS CLEANERS AVAILABLE WHICH ARE FAR SUPERIOR TO REGULAR GLASS AND OVEN CLEANERS.**

The door can be swung open in order to clean the glass. First, lift the firescreen completely and remove any objects that may be on the hearth that could prevent the glass door from opening. Close the door completely and then using the removable handle tip as a screw driver unlock both handles on the right of the door by turning the latch a quarter turn counterclockwise (see Figure 31). Once both handles are unlocked, simply pull the glass door free from the guillotine frame. You may need to slightly lift the door. Be careful not to lift too high or the door may bind against the firescreen.

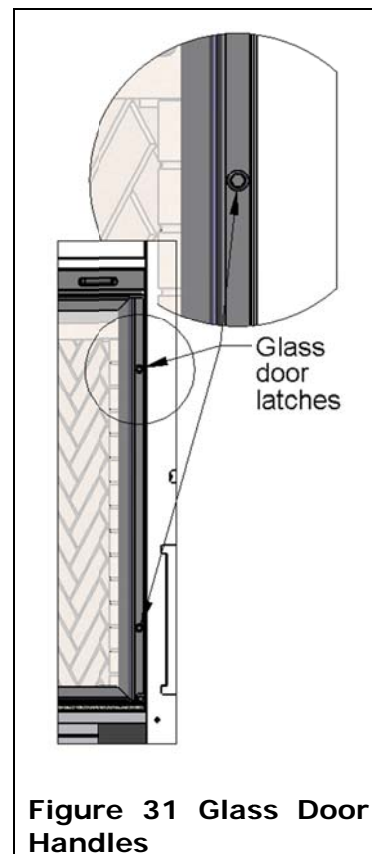

**Figure 31 Glass Door Handles**

### CHIMNEY CLEANING

A fireplace such as the RUMFORD 1000 does not produce a lot of creosote, but the chimney should nevertheless be inspected for creosote buildup after a couple of months of using it. This will allow you to visualize the amount of creosote that is accumulating

and adjust the rate of chimney inspection accordingly. Depending on how you burn your RUMFORD 1000, you may need to clean your chimney every year or every other year.

A buildup of ¼" or more should be cleaned before more creosote accumulates. Use a 10" round brush.

## DISPOSAL OF ASHES

Remove the ashes before they become too deep, i.e., before you have a spillage problem over the ash step refractory brick.

The ashes should be placed in a metal container with a tight-fitting lid. The closed container of ashes should be placed on a non-combustible floor or on the ground, well away from all combustible materials pending final disposal. If the ashes are disposed of by burial, or otherwise locally dispersed, they should be retained in the closed container until all cinders have thoroughly cooled.

## GUILLOTINE SYSTEM

Components of the guillotine system have been designed to limit the requirement for maintenance and overhaul.

The guillotine door and firescreen are designed to operate without having to exert force. If at any time you feel like you have to apply force to get the door or the firescreen moving something is wrong. Do not force it, you could damage or break something.

To ensure easy operation of both the guillotine door and the firescreen, we recommend that you lubricate the guide rails at the beginning of every burning season. Completely open the firescreen and the guillotine door. Apply a quantity of the high temperature grease provided with the fireplace (regular grease will not withstand the heat of the fireplace) on each guide rail (left and right) just below the bottom of the door and move your door up and down a couple of times to distribute the grease all over the guide rail. Repeat for the firescreen. You can purchase additional high temperature grease from your Renaissance dealer.

---

**WARNING: DO NOT USE TEFLON-BASED OR SILICON-BASED PRODUCTS SUCH AS JIG-A-LOO BECAUSE THEY ARE NOT MEANT TO BE USED IN A HIGH TEMPERATURE ENVIRONMENT. BURNED TEFLON TURNS INTO A DEADLY FUME.**

---



If for any reason, you need to dismantle the guillotine system, complete instructions are available on our web site: [www.renaissancefireplaces.com/en/installation-manuals](http://www.renaissancefireplaces.com/en/installation-manuals).

## GUILLOTINE DOOR'S SEAL

The design of the guillotine door requires many gaskets to create a seal adequate enough for the air wash to keep the glass clean (see Figure 32).

1. There is a fiberglass gasket around the glass. If you ever need to change the glass, this gasket will need to be changed as well.
2. There is another fiberglass gasket on the back side of the glass door to seal it against the guillotine door frame. This gasket will need to be changed every second or third year depending on how often you open the glass door on its hinge. It will also need to be removed and changed if you ever need to change the glass.
3. There is a stainless steel gasket that seals the top of the guillotine door frame against the fireplace. It is on the back side of the top of the guillotine door frame. This gasket will rarely need to be changed.
4. There is a stainless steel gasket that seals the bottom of the guillotine door frame against the hearth threshold. It is on the bottom of the guillotine door frame. The

rate of replacement will vary depending on how careful you are at keeping the hearth threshold clean before closing the guillotine door.

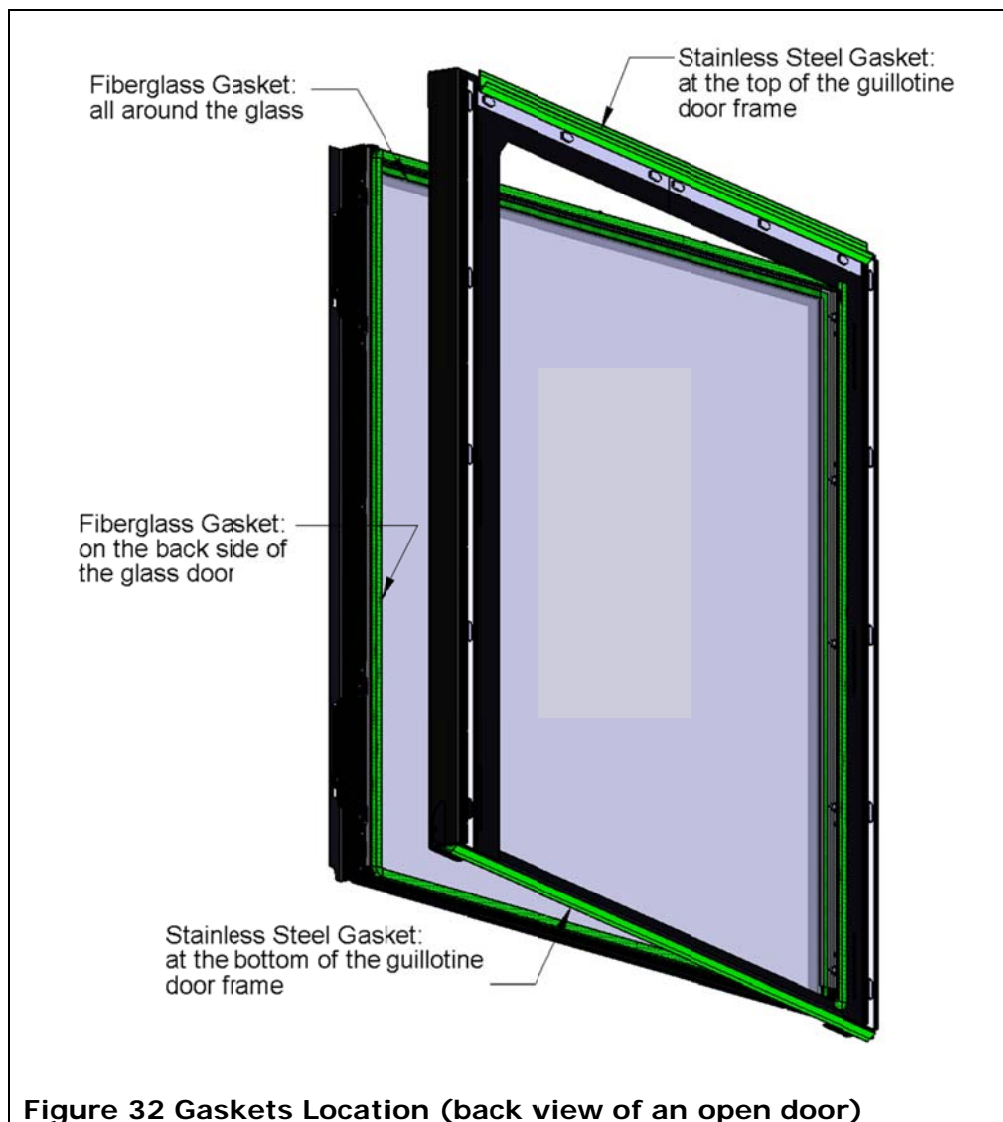

**Figure 32 Gaskets Location (back view of an open door)**

The glass door can also be adjusted in the guillotine door frame in order to close properly on the glass door gasket.

If required, the right side of the glass door can be tightened/loosened by adjusting both pins that latch the glass door:

1. Loosen the screws that hold each pin plate in place,
2. Slightly push the pin plate to tighten the glass door or slightly pull the pin plate to loosen,
3. Retighten the screws.

There is no need to over-tighten the glass door.

If required, the left side of the glass door can be tighten/loosen by adjusting the position of the hinge on both the glass door and the guillotine door frame. You can adjust the hinge to the glass door, the glass door will then move in or out with respect to the hinge and the guillotine door frame.

1. Slightly loosen the screws holding the hinge to the glass door.

2. With the door open, gently pull the glass door away from the hinge pin. This will move the glass door slightly closer to the guillotine door frame when it is closed.
3. Retighten all the hinge screws on the glass door.

You can also adjust the hinge to the guillotine door frame, the glass door and the hinge will then be moved in or out with respect to the guillotine door frame.

4. Slightly loosen the screws holding the hinge to the guillotine door frame.
5. With the door open, gently push the glass door with the hinge towards the firebox. This will move the glass door and the hinge slightly closer to the guillotine door frame when it is closed.
6. Retighten all the hinge screws on the guillotine door frame.

You can also adjust the hinge on both sides to minimize the esthetic impact of the adjustment.



While burning your fireplace with the door closed, if you see the flames coming close to the glass, burning more on one side, or simply not burning nicely, you may need to change one of the gaskets.



## LISTING LABEL

The listing label has been placed on the left counterweight channel. To be able to consult the label, fully open the firescreen and guillotine door. Use a portable lamp and look left in the guillotine bay.

RENAISSANCE RUMFORD		LISTED FACTORY-BUILT FIREPLACE
<b>COMPONENTS REQUIRED FOR INSTALLATION:</b> •USE 4 IN. OR 5 IN. (102 OR 130MM) DIAMETER FLEXIBLE DUCT AND COMBUSTION AIR INLET ASSEMBLY. •USE THE ICC MODEL 10 IN.(254 MM) RIS CHIMNEY AND LISTED COMPONENTS AS PER INSTALLATION INSTRUCTIONS. •MODEL 1000H: A GRAVITY VENT SYSTEM MUST BE INSTALLED IN ACCORDANCE WITH THE MANUFACTURER'S INSTALLATION INSTRUCTIONS MANUAL. •REFER TO MANUFACTURER'S INSTALLATION AND OPERATING INSTRUCTIONS FOR OPTIONAL COMPONENTS. •INSTALL AND USE ONLY IN ACCORDANCE WITH THE MANUFACTURER'S INSTALLATION AND OPERATING INSTRUCTIONS. •DO NOT OBSTRUCT COMBUSTION AIR INLET. •A FIREPLACE INSTALLED WITHOUT OUTSIDE PROVISION AIR COULD STARVE OTHER FUEL BURNING APPLIANCES OF COMBUSTION, VENTILATION AND DILUTION AIR AS A RESULT OF FIREPLACE OPERATION. •DO NOT USE A FIREPLACE INSERT OR OTHER PRODUCTS NOT SPECIFIED FOR USE IN THIS PRODUCT. •COMBUSTIBLE MATERIALS OTHER THAN MANTLE OR SHELF ARE NOT PERMITTED ON FACE OF UNIT. •COMBUSTIBLE FLOOR MUST BE PROTECTED AS SPECIFIED IN THE INSTALLATION INSTRUCTIONS MANUAL. •GAS LOG SHALL BE CERTIFIED FOR THE APPLICATION. WHEN INSTALLED, THE CHIMNEY DAMPER SHALL BE PERMANENTLY SECURE IN AN OPEN POSITION TO EFFECTIVELY VENT THE APPLIANCE. •WARNING: THIS FIREPLACE HAS NOT BEEN TESTED WITH AN UNVENTED GAS LOG SET. TO REDUCE RISK OF FIRE OR INJURY, DO NOT INSTALL AN UNVENTED GAS LOG SET INTO FIREPLACE. •REPLACE GLASS ONLY WITH 5MM CERAMIC GLASS. •OPERATE ONLY WITH FIREBRICKS IN PLACE. •FOR USE WITH SOLID WOOD FUEL ONLY. •MODELS 1000 AND 1000H: OPERATE THIS FIREPLACE WITH THE DOOR CLOSED OR THE FIRESCREEN CLOSED. •MODEL 1000CD: OPERATE THIS FIREPLACE WITH THE DOOR CLOSED ONLY. •DO NOT OVERFIRE UNIT.		
<b>MINIMUM CLEARANCES TO COMBUSTIBLE MATERIALS</b>		
*HEIGHT OF MANTEL (OR SHELF): 0-6 IN. (0-152 MM DEEP)	SIDEWALL	24 IN. / 610 MM FROM FIREPLACE OPENING
*MANTEL POSTS; 0-3 IN. (0-76 MM DEEP)	UNIT TOP, BACK, SIDES AND BOTTOM	6 IN. / 152 MM FROM FIREPLACE OPENING
		6 IN. / 152 MM FROM FIREPLACE OPENING
		0 IN. / 0 MM TO SPACERS
*SEE INSTALLATION INSTRUCTIONS FOR OTHER SPECIFICATIONS OF MANTEL, SHELF AND / OR MANTEL POSTS.		
		

	MODEL / MODÈLE <input type="checkbox"/> 1000 <input type="checkbox"/> 1000CD
CONFORMS TO / CONFORME À UL STD 127 CERTIFIED TO / CERTIFIÉ SELON ULC STD S610	
DO NOT REMOVE THIS LABEL NE PAS ENLEVER CETTE ÉTIQUETTE	
	
SERIAL NO. / NO DE SÉRIE DATE MANUFACTURED / DATE DE FABRICATION	
	
MANUFACTURED BY / FABRIQUÉ PAR ICC INDUSTRIAL CHIMNEY COMPANY INC. CC COMPAGNIE DE CHEMINÉES INDUSTRIELLES INC. 400 J-F KENNEDY, ST-JEROME QUEBEC, CANADA, J7Y 4B7	
MADE IN CANADA FABRIQUÉ AU CANADA	
936201	

FOYER PRÉFABRIQUÉ HOMOLOGUÉ		RENAISSANCE RUMFORD
<b>PIÈCES REQUISES POUR L'INSTALLATION:</b> •TUYAU FLEXIBLE DE 4" OU 5" (102 OU 130MM) ØA. ET PRISE D'ENTRÉE D'AIR. •UTILISER UNE CHEMINÉE RIS 10" (254 MM) DE DIAMÈTRE D'ICC ET SES COMPOSANTS HOMOLOGUÉS SELON LES INSTRUCTIONS D'INSTALLATION. •MODÈLE 1000H: LE SYSTÈME D'ÉVENT PAR GRAVITÉ DOIT ÊTRE INSTALLÉ SELON LES INSTRUCTIONS DU LIVRET D'INSTALLATION DU FABRICANT. •VOIR LES INSTRUCTIONS D'INSTALLATION DU FABRICANT POUR LES COMPOSANTS OPTIONNELS. •INSTALLER ET UTILISER SELON LES INSTRUCTIONS D'INSTALLATION ET DE FONCTIONNEMENT DU FABRICANT. •NE PAS OBSTRUER L'ENTRÉE D'AIR DE COMBUSTION. •D'AUTRES APPAREILS DE CHAUFFAGE À COMBUSTIBLE RISQUERAIENT DE MANQUER D'AIR DE COMBUSTION, DE VENTILATION ET DE DILUTION SI LE FOYER FONCTIONNE SANS ENTRÉE D'AIR EXTÉRIEUR. •NE PAS UTILISER D'ENCASTRABLE OU AUTRES PRODUITS NON SPÉCIFIÉS POUR UTILISATION AVEC CE PRODUIT. •LES MATÉRIEAUX COMBUSTIBLES AUTRES QUE LE MANTEAU DE CHEMINÉE ET/OU TABLETTE NE SONT PAS PERMIS SUR LA FAÇADE DE L'APPAREIL. •UN PLANCHER COMBUSTIBLE DOIT ÊTRE PROTÉGÉ SELON LES SPÉCIFICATIONS DU LIVRET D'INSTRUCTIONS. •LES BÛCHES AU GAZ DOIVENT ÊTRE CERTIFIÉES POUR L'APPLICATION. LORSQU'IL EST INSTALLÉ, LE REGISTRE DE LA CHEMINÉE DOIT ÊTRE FIXÉ DE FAÇON PERMANENTE EN POSITION OUVERTE AFIN D'ASSURER LA VENTILATION EFFICACE DE L'APPAREIL. •LE REMPLACEMENT D'UNE VITRE DOIT SE FAIRE AVEC UNE VITRE CÉRAMIQUE DE 5MM D'ÉPAISSEUR SEULEMENT. •FAIRE FONCTIONNER UNIQUEMENT AVEC LES PIERRES RÉFRACTAIRES EN PLACE. •POUR UTILISATION AVEC DU BOIS SEULEMENT. •MODÈLES 1000 ET 1000H: FAIRE FONCTIONNER LE FOYER AVEC LA PORTE FERMÉE OU AVEC LE PARE-ÉTINCELLES FERMÉ. •MODÈLE 1000CD: FAIRE FONCTIONNER LE FOYER AVEC LA PORTE FERMÉE SEULEMENT. •NE PAS SURCHAUFFER L'APPAREIL.		
<b>DÉGAGEMENTS MINIMAUX AUX MATIÈRES COMBUSTIBLES</b>		
*HAUTEUR DU MANTEAU DE CHEMINÉE (OU TABLETTE): 0-6 PO. (0-152 MM) DE PROFOND	MUR DE CÔTÉ	24 PO. / 610 MM DE L'OUVERTURE DU FOYER
*COLONNES DE MANTEAU DE CHEMINÉE; 0-3 PO. (0-76 MM) DE PROFOND	DESSUS, ARRIÈRE, CÔTÉS ET BASE DE L'APPAREIL	6 PO. / 152 MM DE L'OUVERTURE DU FOYER
		6 PO. / 152 MM DE L'OUVERTURE DU FOYER
		0 PO. / 0 MM DES CALES
*VOIR LE LIVRET D'INSTALLATION POUR AUTRES SPÉCIFICATIONS DU MANTEAU DE CHEMINÉE, DE LA TABLETTE ET / OU DES COLONNES DE MANTEAU DE CHEMINÉE.		
		

## REPLACEMENT PARTS

A complete list of replacement parts is available on our web site:  
[www.renaissancefireplaces.com](http://www.renaissancefireplaces.com)



## 30 YEAR LIMITED WARRANTY

### FOR RENAISSANCE FIREPLACES™

All **Renaissance Fireplaces™** models are warranted against defects in material and workmanship for a period of 30 years, subject to the following conditions:

During the first year **Renaissance Fireplaces™** will repair or replace, at our option, any parts which upon examination by an authorized **Renaissance Fireplaces™** representative, are found to be defective, except the parts listed in the EXCLUSIONS portion of this warranty. **Renaissance Fireplaces™** will also pay reasonable labor costs for the repair work.

During the second through fifth years **Renaissance Fireplaces™** will repair or replace, at our option, any parts which upon examination by an authorized **Renaissance Fireplaces™** representative, are found to be defective, except the parts listed in the EXCLUSIONS portion of this warranty. **Renaissance Fireplaces™** shall not be responsible for any labor costs associated with this repair work.

During the sixth through thirtieth years **Renaissance Fireplaces™** will provide replacement parts, if available, at 50% of the published retail price, except for the parts listed in the EXCLUSIONS portion of this warranty. **Renaissance Fireplaces™** shall not be responsible for any labor costs associated with this repair work.

#### EXCLUSIONS:

- Glass and andirons.
- Damage due to normal wear and tear, such as paint discoloration, worn gaskets, eroded or cracked rigid insulation panels or firebox lining.
- Repairs or replacements necessitated by vandalism, neglect, abuse, over-firing, improper fuel or fuel loads, or failure to adequately service the unit, as stated in the owner's manual.
- Repairs or replacements (particularly charges for travel and labor) not authorized by **Renaissance Fireplaces™** in advance.

#### LIMITATIONS:

- All items found to be defective will be replaced or repaired upon return of the defective part to an authorized **Renaissance Fireplaces™** dealer. **Renaissance Fireplaces™** will not be responsible for freight costs related to shipping replacement parts.
- Any complete fireplace, or part thereof, that is replaced or serviced under this warranty, will be warranted for a period not exceeding the remaining term of the original warranty.
- This warranty is not transferable.
- This warranty does not apply to damage to the appliance while in transit.
- This warranty does not apply if the installation does not conform to the installation requirements in the owner's manual.
- **Renaissance Fireplaces™** is free of liability for any damages caused by the appliance, as well as material and labor charges incurred in the removal or re-installation of any **Renaissance Fireplaces™** fireplace under this warranty. Incidental or consequential damages are not covered by this warranty.
- The remedies set forth herein are exclusive, and the liability of the seller shall not exceed the price of the fireplace or part thereof upon which the liability is based.

- This warranty is expressly in lieu of all other warranties expressed or implied, including the warranties of merchantability and fitness for use and all other obligations or liabilities on the part of **Renaissance Fireplaces™**.

PLEASE VISIT OUR WEBSITE FOR MORE INFORMATION  
[WWW.RENAISSANCEFIREPLACES.COM](http://WWW.RENAISSANCEFIREPLACES.COM)

RENAISSANCE FIREPLACES™, A DIVISION OF:  
INDUSTRIAL CHIMNEY COMPANY  
400 J-F KENNEDY  
ST. JEROME (QUEBEC)  
CANADA J7Y 4B7  
TELEPHONE: (450) 565-6336  
FAX: (450) 565-6519

