



CLEAN DOESN'T MEAN COMPROMISE

LINEAR 50 SP INSTALLATION MANUAL



We strongly recommend that our products be installed and serviced by professionals who are certified by the National Fireplace Institute in the U.S. or by Wood Energy Technology Transfer Inc. in Canada.



 <p>FIREPLACE- FIRE CHAMBER FOR USE WITH ICC CERTIFIED MODEL RESIDENTIAL TYPE AND BUILDING HEATING APPLIANCE CHIMNEY NUMBER: [REDACTED]</p> <p>SAFETY US-CA SÉCURITÉ US-CA MH61405</p> <p>SERIAL NO. / NO DE SÉRIE: [REDACTED]</p> <p>DATE MANUFACTURED / DATE DE FABRICATION MADE IN CANADA BY / FABRIQUÉ AU CANADA PAR ICC, 400 J.F. KENNEDY, ST.-JEROME, QC, CANADA, J7Y 4B7</p>	<p>RENAISSANCE LINÉAIRE 50 SP FOYER PRÉFABRIQUÉ ET APPAREIL DE CHAUFFAGE HOMOLOGUÉ</p> <p>NE PAS ENLEVER CETTE ÉTIQUETTE MIS À L'ESSAI SELON LES NORMES: UL 127 / CAN/ULC-S610</p> <p>PIÈCES REQUISES POUR L'INSTALLATION:</p> <ul style="list-style-type: none"> ◆ TUYAU FLEXIBLE DE 4" OU 5" (102 OU 127 MM) DE DIAMÈTRE ET PRISE D'ENTRÉE D'AIR. ◆ UTILISER UNE CHEMINÉE RIS 10" (254 MM) OU EXCEL 8" (203 MM) DE DIAMÈTRE D'ICC ET SES COMPOSANTS HOMOLOGUÉS SELON LES INSTRUCTIONS D'INSTALLATION. ◆ DEUX ÉVÉNEMENTS PAR GRAVITÉ ET DEUX ENTRÉES D'AIR AMBIANT DOIVENT ÊTRE INSTALLÉS SELON LES INSTRUCTIONS DU LIVRET D'INSTALLATION DU FABRICANT. ◆ VOIR LES INSTRUCTIONS D'INSTALLATION DU FABRICANT POUR LES COMPOSANTS OPTIONNELS. <p>◆ INSTALLER ET UTILISER SELON LES INSTRUCTIONS D'INSTALLATION ET DE FONCTIONNEMENT DU FABRICANT. ◆ NE PAS OBSTRUER L'ENTRÉE D'AIR DE COMBUSTION. ◆ D'AUTRES APPAREILS DE CHAUFFAGE À COMBUSTIBLE RISQUERAIENT DE MANQUER D'AIR DE COMBUSTION, DE VENTILATION ET DE DILUTION SI LE FOYER FONCTIONNE SANS ENTRÉE D'AIR EXTÉRIEUR. ◆ NE PAS UTILISER D'ENCASTRABLE OU AUTRES PRODUITS NON SPÉCIFIÉS POUR UTILISATION AVEC CE PRODUIT. ◆ LES MATÉRIAUX COMBUSTIBLES AUTRES QUE LA TABLETTE D'UN MANTEAU DE CHEMINÉE NE SONT PAS PERMIS SUR LA FAÇADE DE L'APPAREIL. ◆ UN PLANCHER COMBUSTIBLE DOIT ÊTRE PROTÉGÉ SELON LES SPÉCIFICATIONS DU LIVRET D'INSTRUCTIONS. ◆ LES BŒCHES AU GAZ DOIVENT ÊTRE CERTIFIÉES POUR L'APPLICATION. LE REGISTRE DE LA CHEMINÉE DOIT ÊTRE FIXÉ DE FAÇON PERMANENTE EN POSITION OUVERTE AFIN D'ASSURER LA VENTILATION EFFICACE DE L'APPAREIL. ◆ AVERTISSEMENT: CE FOYER N'A PAS ÉTÉ TESTÉ AVEC UNE BŒCHE À GAZ SANS ÉVÉNEMENT. POUR RÉDUIRE LES RISQUES DE FEU ET DE BLESSURES, NE PAS INSTALLER DE BŒCHE À GAZ SANS ÉVÉNEMENT DANS CE FOYER. ◆ LE REMPLACEMENT D'UNE VITRE DOIT SE FAIRE AVEC UNE VITRE CÉRAMIQUE DE 5MM D'ÉPAISSEUR SEULEMENT. ◆ FAIRE FONCTIONNER UNIQUEMENT AVEC LES PIERRES RÉFRACTAIRES EN PLACE. ◆ POUR UTILISATION AVEC DU BOIS SEULEMENT. ◆ FAIRE FONCTIONNER LE FOYER AVEC LA PORTE FERMÉE. ◆ NE PAS SURCHAUFFER L'APPAREIL. ◆ CONVIENT AUX BÂTIMENTS TRANSPORTABLES. </p>							
	<p>DÉGAGEMENTS MINIMAUX AUX MATIÈRES COMBUSTIBLES</p> <table border="1"> <tr> <td>MUR DE CÔTÉ</td> <td>24 PO. / 610 MM DE L'OUVERTURE DU FOYER</td> </tr> <tr> <td>HAUTEUR DE LA TABLETTE DU MANTEAU DE CHEMINÉE</td> <td>14 PO. / 355 MM DE L'OUVERTURE DU FOYER</td> </tr> <tr> <td>0-12 PO. (0-305 MM) DE PROFOND</td> <td></td> </tr> <tr> <td>DESSUS, ARRIÈRE, CÔTÉS ET BASE DE L'APPAREIL</td> <td>0 PO. / 0 MM DES CALES</td> </tr> </table>	MUR DE CÔTÉ	24 PO. / 610 MM DE L'OUVERTURE DU FOYER	HAUTEUR DE LA TABLETTE DU MANTEAU DE CHEMINÉE	14 PO. / 355 MM DE L'OUVERTURE DU FOYER	0-12 PO. (0-305 MM) DE PROFOND		DESSUS, ARRIÈRE, CÔTÉS ET BASE DE L'APPAREIL
MUR DE CÔTÉ	24 PO. / 610 MM DE L'OUVERTURE DU FOYER							
HAUTEUR DE LA TABLETTE DU MANTEAU DE CHEMINÉE	14 PO. / 355 MM DE L'OUVERTURE DU FOYER							
0-12 PO. (0-305 MM) DE PROFOND								
DESSUS, ARRIÈRE, CÔTÉS ET BASE DE L'APPAREIL	0 PO. / 0 MM DES CALES							



The listing label has been placed inside the firebox, under the insulation below the front right refractory brick. Take the time to take note of the fireplace serial number for future reference. The serial number also appears on a label on your owner's manual bag.

Keep these instructions for future use.

Dear Installer,

The Renaissance LINEAR 50 SP is a member of the Renaissance Fireplaces family of ultra-high-end fireplaces. The LINEAR 50 SP is unique in its design. The 50" wide opening provides an enormous linear space to watch the fire. It combines technology with elegance, allowing you to enjoy an open fire in a modern fashion.

We have designed your new Renaissance LINEAR 50 SP to be easy to install, operate, and maintain. It is critical for you to study this manual to be sure that the installation is correct, and then also to be familiar with the guidelines for operation and maintenance **contained in the Owner's Manual**. Be sure to present both manuals to the owner or leave them in a prominent place.

We at Renaissance Fireplaces™ appreciate the importance of careful work and professional knowledge in installing this fireplace system exactly according to the instructions.

Sincerely,

Renaissance Fireplaces™ Team

August 2017

Industrial Chimney Company Inc.
400 J.-F. Kennedy, St-Jerome,
QC, Canada, J7Y 4B7
Telephone: (450) 565-6336
www.icc-rsf.com

TABLE OF CONTENTS

IMPORTANT INSTALLATION SAFETY PRECAUTIONS	4
Do's AND DON'TS	4
Combustible vs Non-combustible Materials	4
GENERAL SPECIFICATIONS	5
OPTIONS	5
FIREPLACE	7
HEAT REDISTRIBUTION SYSTEM (HRS)	8
MANTEL	8
CHIMNEY	9
PLANNING THE INSTALLATION:	10
SELECTING A LOCATION IN THE HOUSE	13
Performance Considerations	13
Restrictions	13
FACTORS AFFECTING LOCATION IN A ROOM	13
Room Placement Options	13
Flooring Requirements	13
Ceiling Height	13
Fireplace Clearances	14
Mandatory Heat Redistribution System (HRS)	14
CHIMNEY	14
Location of The Chimney	14
Offsetting The Chimney	14
Going Through A Wall	16
Outside Chase Enclosure	17
Chimney Height	17
FIREPLACE INSTALLATION	19
UNPACKING YOUR LINEAR 50 SP	19
MOVING THE LINEAR 50 SP	19
INSTALLING THE BOTTOM STANDOFFS	20
LIFTING THE FIREPLACE	20
SECURING THE FIREPLACE	21
HEAT REDISTRIBUTION SYSTEM (HRS) INSTALLATION	21
HRS Air Intakes	21
HRS Air Outlets	22
OUTSIDE AIR DUCT	23
CHIMNEY INSTALLATION	24
TO OFFSET THE CHIMNEY	26
Through the Wall Offset	26
FINISHING	27
FIREPLACE FACING	27
Installing The Cement Board Panels	27
Covering The Fireplace Facing	27
HEARTH EXTENSION	28
Raised Hearth Extension	29
MANTEL	30
FIREBOX LINING INSTALLATION	30
GLASS CLEANING	31
REPLACEMENT PARTS	31
WARRANTY	31

IMPORTANT INSTALLATION SAFETY PRECAUTIONS

DO'S AND DON'TS

If this fireplace is not properly installed, a house fire could result. For issues of safety and liability, follow the installation directions carefully. Contact your local authority having jurisdiction (such as municipal building department or fire department) regarding restrictions and installation requirements, and the need to obtain a permit.

To ANYONE installing this fireplace: these DO's and **DON'Ts** are for proper performance and safety of this fireplace system, as well as for your personal safety and protection. **Detailed explanations follow in this manual and in the Owner's Manual.**

1. DO read this entire manual and the **Owner's manual** before installing this fireplace system.
2. DO exercise caution in moving and placing the fireplace. See "Moving The LINEAR 50 SP" on page 19 for detailed instructions.
3. DO inspect the fireplace, chimney, and parts/components for damage before installation.
4. DO install all required parts/components as instructed in this manual.
5. DO be aware of differences in installation procedures and specifications for this fireplace and other similar products.
6. DO NOT modify the fireplace and do not install any parts/components not approved for use with this fireplace.
7. DO NOT install an unvented gas log set, gas lighter, wood burning fireplace insert of other products not specified for use with or in this fireplace.
8. DO NOT **over fire this unit in testing or demonstrating it. See Owner's Manual** for details about proper operation.
9. DO NOT allow combustible materials closer to heat sources (fireplace and chimney) than allowed in minimum clearance instructions.
10. DO NOT allow non-combustible materials such as insulation in required air spaces (e.g. insulation contacting the chimney).
11. DO NOT install an insert in this fireplace.

COMBUSTIBLE VS NON-COMBUSTIBLE MATERIALS

It is important to distinguish clearly between combustible and non-combustible materials. National Fire Protection Association (NFPA) defines the differences:

Combustible Materials

- Materials made of or surfaced with any of wood, plant fibers, plywood/OSB, compressed paper, plastic, gypsum board (drywall/sheetrock)¹

¹ Note that gypsum board, whether fire-rated or not is considered combustible.

- Any material that can ignite and burn, whether it is flame-proofed or not, plastered or not

Non-combustible Materials

- Materials that, as used and under anticipated conditions, will not ignite, burn, support combustion, or release combustible vapors when subjected to flame or heat
- Materials reported as passing ASTM E 136, Standard Test Method for Behavior of Materials in a Vertical Tube Furnace at 750°C².

GENERAL SPECIFICATIONS

The LINEAR 50 SP fireplace is a decorative fireplace that provides a magnificent view of the fire. It is defined as a fireplace (primarily for aesthetics) under the 2015 EPA (United States Environmental Protection Agency) regulation since it offers more than 500 square inches of pure fire viewing (682 square inches are visible). Small amounts of firewood can fill the firebox with large, beautiful flames in this exceptional fireplace.

OPTIONS

The LINEAR 50 SP can be installed with two different chimney systems:

- 10" RIS: you will need to use the EO-10SPAP to be able to connect the 10" RIS chimney to your fireplace;
- 8" EXCEL: you will need to use the EO-08SPAP to be able to connect the 8" EXCEL chimney to your fireplace.

Be aware that the requirements for minimum chimney height are not the same for the two chimney systems (see Table 4). Make sure you plan accordingly.

The Heat Redistribution System (HRS) is mandatory and requires the installation of intakes and outlets to allow ambient air in and warmed air out of the fireplace. Included with the fireplace are two air intake grills, two hot air outlets and two insulated flexible ducts with the outlet grill adapters. We also offer different styles of grills in option:

- If you would prefer one long linear grill for the hot air outlet (above the fireplace) instead of two rectangular outlet grills, we offer the Long Linear Outlet Grill (EO-LLG-OUT). Please refer to the installation instructions of the option for installation restrictions compared to the hot air outlet grills provided.
- You can also change the two rectangular intake grills for one Long Linear Intake Grill (EO-LLG-IN). Please refer to the installation instructions of the option for installation restrictions compared to the rectangular grills provided.
- Installations in an 8' ceiling require specific Air Outlet Grills to ensure adequate heat is vented from the fireplace. The Square Grills for 8' Ceiling (EO-SG) includes two 13" square grills and two outlet grill adapters that are required when the ceiling is only at 8'. Please refer to the installation instructions of the option for installation restrictions compared to the rectangular grills provided.

Vented gas logs sets are permitted, unvented gas logs are not. Go online to the Renaissance web site: www.renaissancefireplaces.com for more information.

² NFPA 211, Chimneys, Fireplaces, Vents, and Solid Fuel-Burning Appliances

WARNING: THIS FIREPLACE HAS NOT BEEN TESTED WITH AN UNVENTED GAS LOG SET. TO REDUCE RISK OF FIRE OR INJURY, DO NOT INSTALL AN UNVENTED GAS LOG SET INTO THIS FIREPLACE. DO NOT INSTALL A GAS LIGHTER BECAUSE THE HEAT PRODUCED BY THE FIREPLACE MAY PERMANENTLY DAMAGE THE GAS LIGHTER.

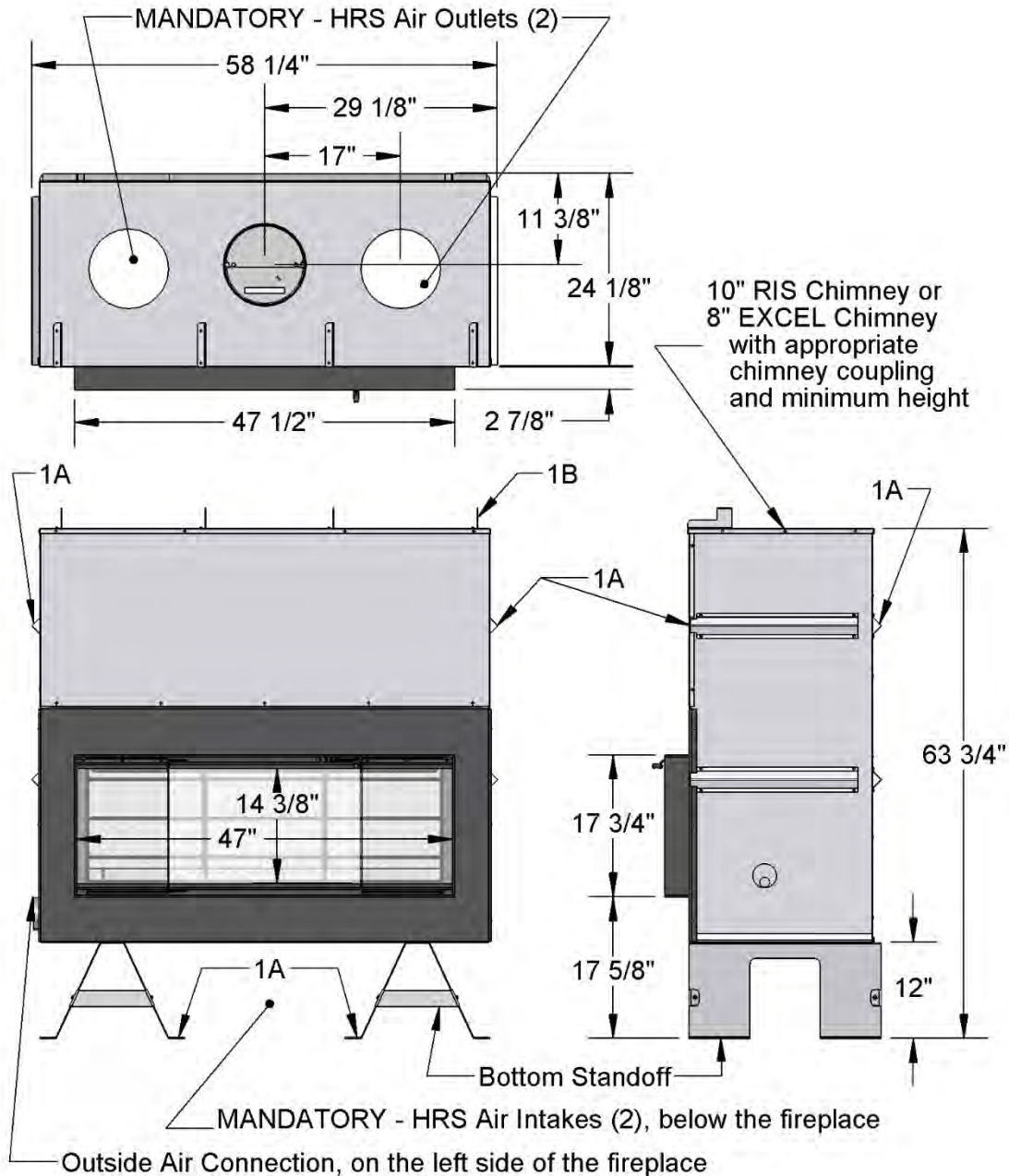

The fireplace bottom standoffs are mandatory for all installations. They permit air flow into the fireplace casing and MUST be installed regardless of whether the fireplace is installed on combustible or non-combustible flooring or platforms. See section "Fireplace Installation: Installing The Bottom Standoffs" for all the details regarding the requirements to use the fireplace bottom standoffs.

FIGURE 1 FIREPLACE DIMENSIONS

FIREPLACE

TABLE 1 FIREPLACE CLEARANCES AND SPECIFICATIONS

Manual Ref.

			Manual Ref.
A	Distance to combustible material from side, back and bottom standoffs.	0" (0 mm)	Figure 1
B	Framing against the top standoff.	Can be combustible	Figure 1
C	Minimum distance from the side of the fireplace opening to a perpendicular side wall.	24" (610 mm)	Figure 2
D	Minimum ceiling height: measured from the bottom of the bottom standoff to the lowest point of the ceiling above the fireplace. Applies both to the inside and outside of the fireplace enclosure.	9' (2.7 m)	Figure 3
E	Minimum depth of non-combustible hearth extension: measured from the front of the fireplace.	16" (406 mm)	Figure 2
F	Minimum width of non-combustible hearth extension, centered on the fireplace opening.	40.5" (1.03 m)	Figure 2
G	Minimum width of the spark guard.	40.5" (1.03 m)	Figure 2

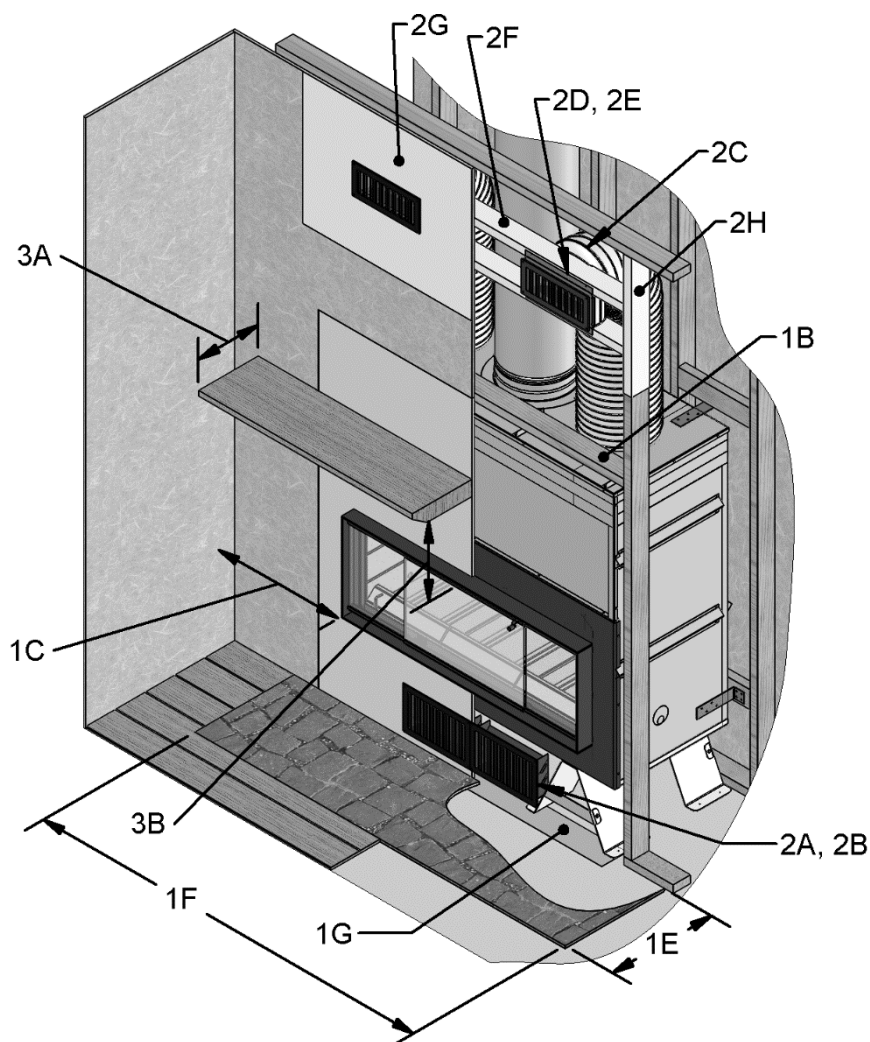

FIGURE 2 FIREPLACE, HRS AND MANTEL CLEARANCES

WARNING: COMBUSTIBLE FRAMING IS NOT PERMITTED IN THE SPACE DIRECTLY ABOVE THE FIREPLACE. THE ONLY EXCEPTION IS FOR FRAMING USED TO SUPPORT THE FACING MATERIAL AND MANTEL BUT SOME RESTRICTIONS APPLY, SEE FIGURE 2, TABLE 1 AND TABLE 2.

THE AREA ABOVE THE FIREPLACE MUST BE FREE OF COMBUSTIBLES FOR AT LEAST THE HEIGHT PROVIDED IN TABLE 1 (D).

HEAT REDISTRIBUTION SYSTEM (HRS)

TABLE 2 HEAT REDISTRIBUTION SYSTEM (HRS) CLEARANCES AND SPECIFICATIONS Manual Ref.

A	Minimum height of the air intake grill above the floor.	1.5" (38 mm)	Figure 2
B	Maximum height of the air intake grill above the floor when the fireplace is sitting on the floor. Height can increase if fireplace is raised.	18" (457 mm)	Figure 2
C	Minimum clearance between the outside of the hot air outlet duct and any combustibles above, below or beside the duct.	6" (152 mm)	Figure 2
D	Minimum clearance from the hot air outlet grill to the ceiling; measured from the top of the outlet grill to the ceiling above.	11" (280 mm)	Figure 2, Figure 11
E	Minimum height of the hot air outlet grill above the top of the fireplace: measured from the bottom edge of the hot air outlet grill to the top of the casing of the fireplace main body.	26" (660 mm)	Figure 2, Figure 11
F	Framing around the hot air outlet grills and their adapters.	Non-combustible	Figure 2, Figure 5, Figure 11
G	Wall surface surrounding the hot air outlet grills.	Non-combustible	Figure 2, Figure 12
H	Minimum height of non-combustible framing for the hot air outlets, centered on the hot air outlet grills.	22" (559 mm)	Figure 2, Figure 5, Figure 11
I	Maximum length of each outlet duct: measured from the top of the fireplace to the outlet grill	15' (4.57 m)	

MANTEL

TABLE 3 MANTEL CLEARANCES AND SPECIFICATIONS Manual Ref.

A	Maximum depth of a combustible mantel shelf above the fireplace opening.	12" (305 mm)	Figure 2
B	Minimum height of a combustible mantel shelf above the top of the fireplace opening: measured from the lowest point/bottom of the combustible mantel.	14" (356 mm)	Figure 2

CHIMNEY

This fireplace is certified for use with ICC chimneys only: 10" RIS or 8" Excel. Please refer to Figure 3 and Table 4 for chimney clearances and specifications with the LINEAR 50 SP fireplace.

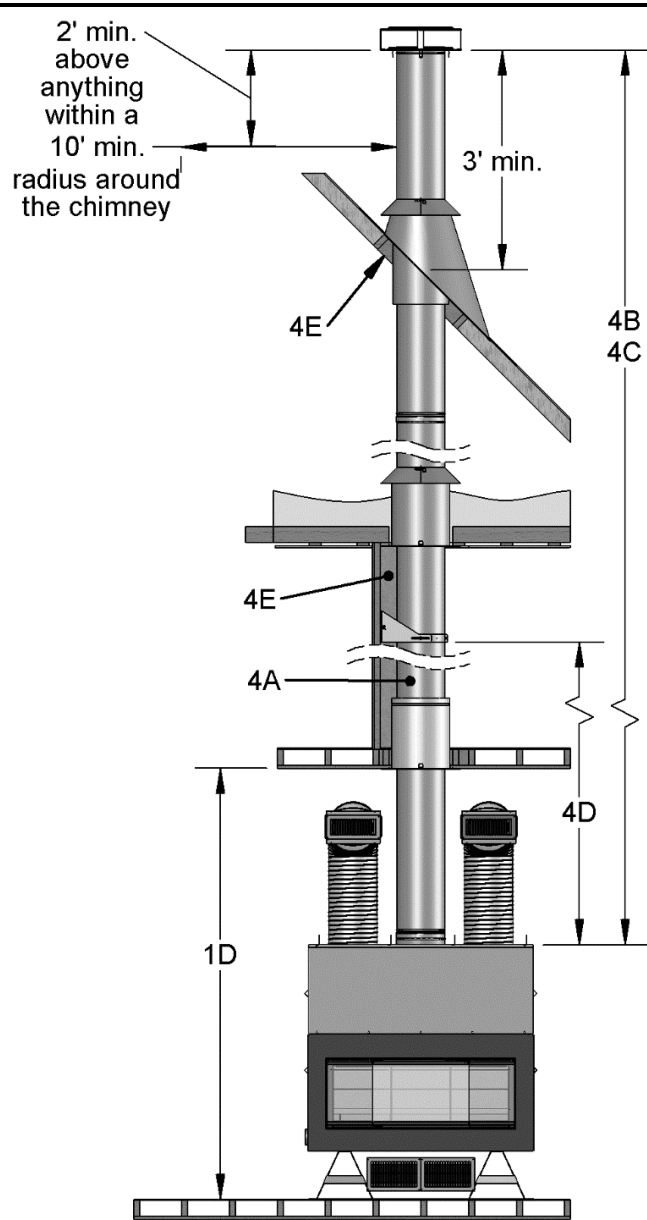

FIGURE 3 GENERAL CHIMNEY REQUIREMENTS

TABLE 4 CHIMNEY CLEARANCES AND SPECIFICATIONS

Manual
Ref.

A	Chimney Size and type	10" RIS	8" Excel	Figure 4, Figure 3
B	Minimum chimney height: minimum total chimney height from the top of the fireplace to the rain cap without offsets.	12' (3.66 m)	18' (5.49 m)	Figure 3, Table 7
C	Maximum chimney height: maximum total chimney height from the top of the fireplace to the rain cap.	38' (11.58 m)	38' (11.58 m)	Figure 3
D	Maximum chimney height supported by the fireplace	12' (3.66 m)	16' (4.88 m)	Figure 3
E	Minimum clearance between the exterior of the chimney and any combustibles	2" (51 mm)	2" (51 mm)	Figure 3

PLANNING THE INSTALLATION: FOLLOWING RECOMMENDATIONS AND MEETING REQUIREMENTS

The planning process may involve a number of people, including sales, estimating, and installing personnel, the local authority having jurisdiction (such as municipal building, fire department, or fire prevention bureau officials, and, of course, the owners who purchase the system. Close attention to detail and clear communication are important in that process.

There are numerous factors and many details that are involved in choosing a suitable location for the fireplace and chimney. Some of these factors are options and recommendations for optimum performance and owner enjoyment. Others are strict requirements that may be essential for acceptable performance and safety.

We introduce recommendations and requirements for planning factors here, but it may be necessary to refer to the installation details in the Installation section that follows for exact details that can affect planning decisions. We strongly recommend that you take the time to plan your entire installation (fireplace, air duct systems, and chimney) before beginning the actual installation (see Figure 4).

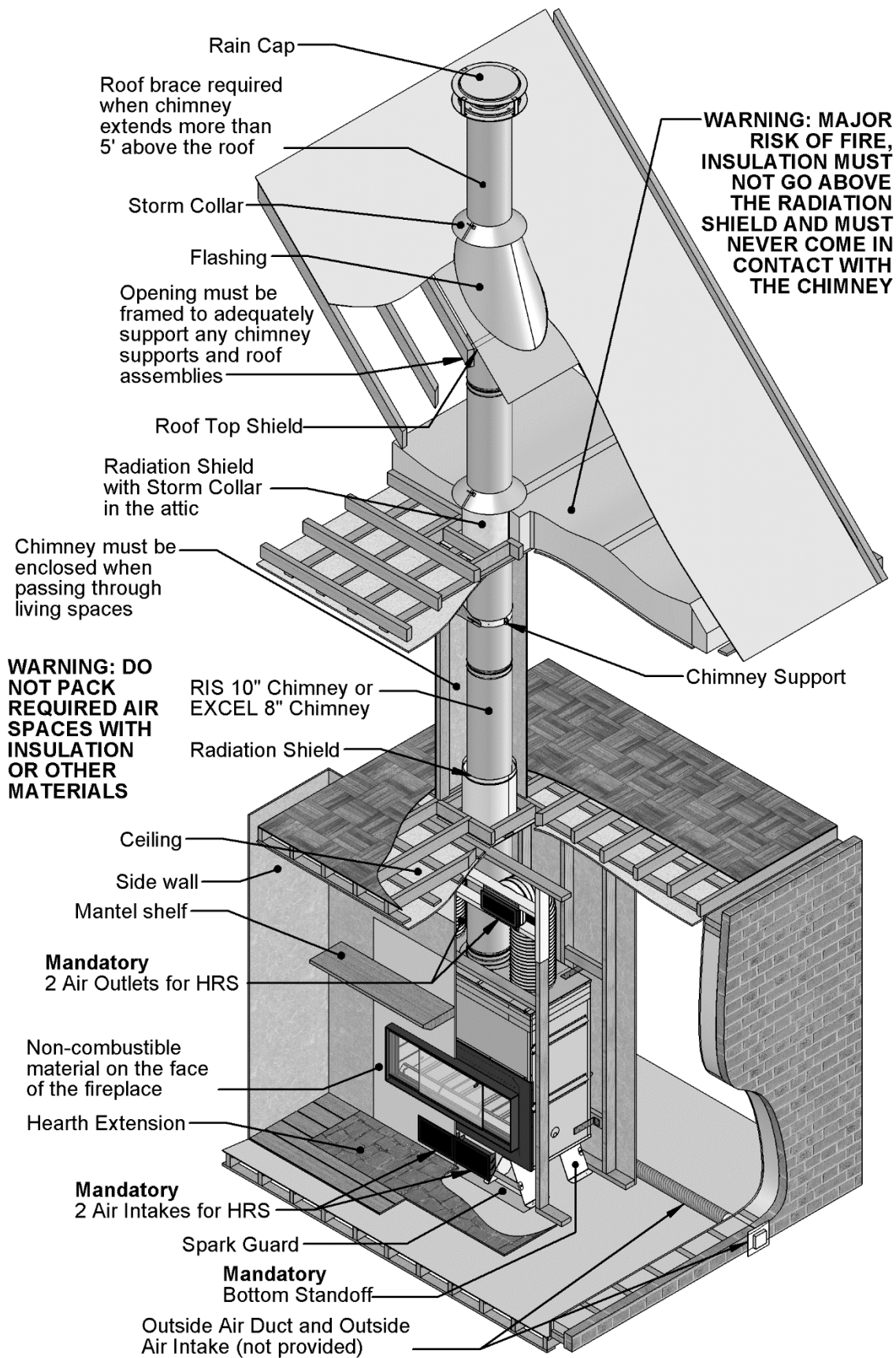
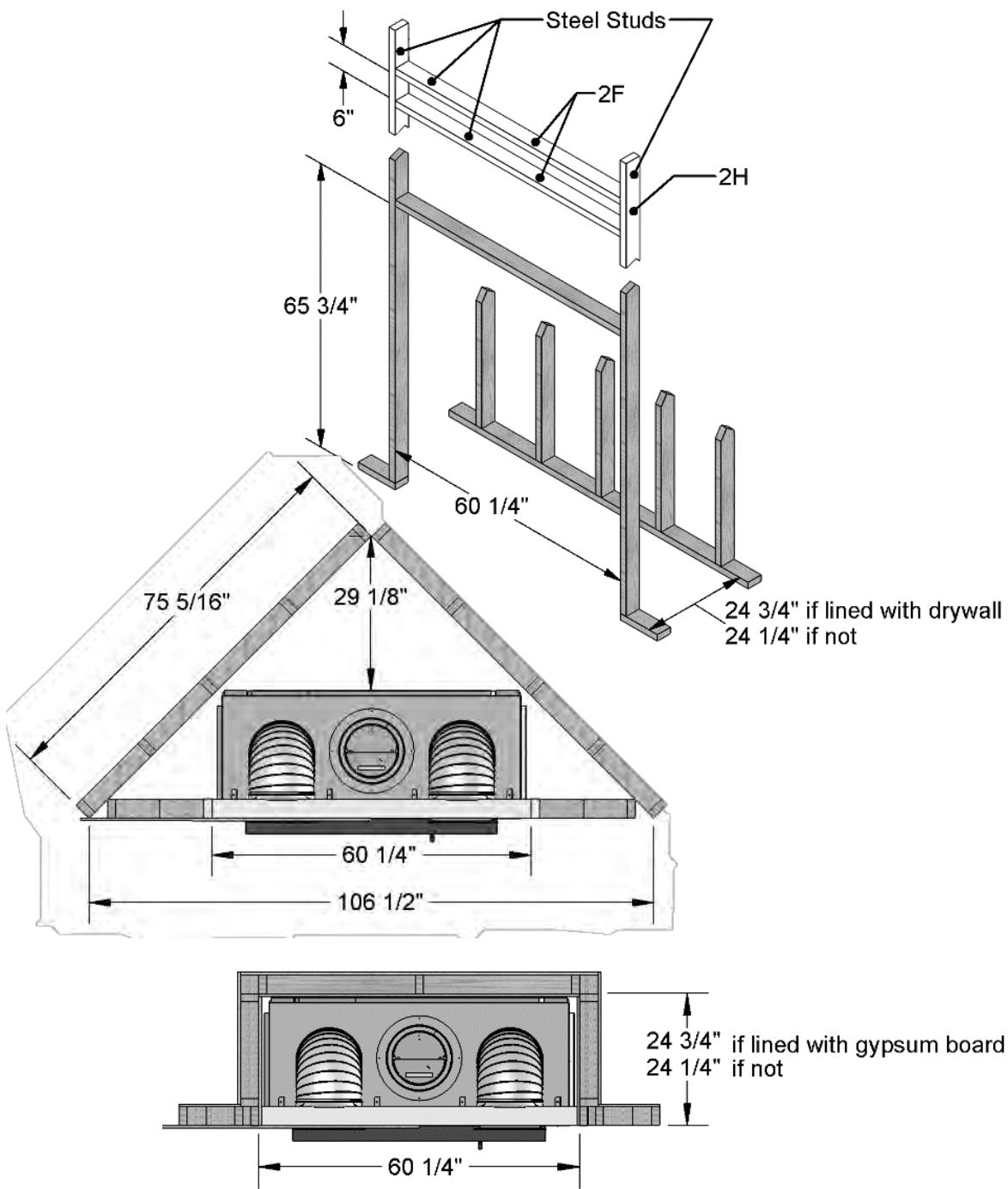

FIGURE 4 GENERAL INSTALLATION



The framing dimensions are larger than required for ease of installation.

All framing around the HRS outlets **MUST** be in steel studs whether they are installed above the fireplace or elsewhere.

FIGURE 5 FRAMING EXAMPLES

SELECTING A LOCATION IN THE HOUSE

PERFORMANCE CONSIDERATIONS

The room in the house where the fireplace may well be determined by its use by the owners. If there are options, the performance of the venting system might be considered:

- Installation where as much of the chimney is within the building envelope (toward the center of the house and with the termination close to the peak of the roof) enhances draft.
- Installation in an insulated chase enclosure may be an acceptable alternative for locations where much of the chimney would be exposed to cold air.

RESTRICTIONS

There are a number of factors that may prevent installation in a particular room (see "Factors Affecting Location in a Room" below), but there are also locations where the installation of this fireplace is prohibited:

- The LINEAR 50 SP must be installed within the vapor barrier of the home.
- It cannot be installed outdoors, or on a three season porch.

FACTORS AFFECTING LOCATION IN A ROOM

With the selection of a particular room in the house, the focus turns to the specific location within the chosen room. The desired location may be dictated by room orientation, furniture arrangement, and other design, comfort, and utility factors. We focus now on installation details that determine whether a chosen location is possible, and what alternatives are available.

ROOM PLACEMENT OPTIONS

The LINEAR 50 SP can be installed in a number of ways in a room: along a wall, as a room divider, across a corner. For each location, there are numerous factors that determine what exactly is possible and where, which we introduce below and provide details for in the "Fireplace Installation" and in the "Chimney Installation" Section.

FLOORING REQUIREMENTS

Before installing your LINEAR 50 SP, make sure the floor surface and floor structure are level and can sustain the weight of the complete fireplace and whatever finishing material you will use to cover the facing of your fireplace.

You can install your fireplace at the floor level or build a platform to elevate it to the desired height. Again, make sure the platform is built to sustain the weight of the fireplace and the finishing material you will use to finish the facing of your fireplace.

You **MUST** install the fireplace onto the fireplace bottom standoff along with the bottom casing provided with the fireplace, whether it is installed on combustible or non-combustible flooring.

If it is installed on a typically framed combustible floor, you must reinforce the sub-floor to help spread the load from the legs of the bottom standoff throughout the floor structure to prevent sagging.

CEILING HEIGHT

The minimum ceiling height is measured from the base of the bottom standoffs to the ceiling. This requirement applies to the ceiling above the fireplace in the enclosure and the ceiling height in the room in front of the fireplace. Refer to Table 1 (D) for the required

height. **This height can be reduced to 8' with** installation of the optional Square Grills for 8' Ceilings (EO-SG).

FIREPLACE CLEARANCES

See Figures 1 and 2 and Table 1 on pages 6, 7 and 7 for complete unit specifications and clearances. Framing examples are provided in Figure 5. It is important to understand and plan for other factors in addition to the clearances to the unit and the chimney:

- No recessed shelves or cupboards can be in the area above the fireplace. This space must be kept empty.
- The enclosure walls can be framed with any suitable materials (2"x4" or 2"x6" studs, plywood, gypsum board, etc.). Because of the high heat output potential of the LINEAR 50 SP, combustible materials must NOT go closer to the fireplace than the back and sides' standoffs; refer to Figure 5.

MANDATORY HEAT REDISTRIBUTION SYSTEM (HRS)

As the firebox heats up, a significant amount of heat builds up in the space between the firebox and the casing that surrounds it. In order to reduce temperatures in this area and deliver more heat into the living space, the LINEAR 50 SP requires installation of a Heat Redistribution System (HRS) which is provided.

The HRS consists of air intakes and air outlets which circulate room air through the space between the casing and the firebox and then return the heated air to the room. The HRS relies on natural draft and does not require a blower or electricity.

There are a number of options for locating the intakes and outlets of the system, as well as important requirements. Proper planning and installation of this system are critical to ensure the safety of the family and their home.

The instructions in this manual are for the HRS system included with the fireplace. If you have purchased another of Renaissance Fireplaces certified grill options, follow the instructions included with that option.

Refer to Table 2 for the HRS clearances and specifications with the LINEAR 50 SP fireplace.

CHIMNEY

LOCATION OF THE CHIMNEY

Note the location of roof and floor joists. Choose a location that does not require cutting them if possible.

We recommend the chimney be installed in the interior of the building as it will provide better performance than an exterior chimney. In areas with continuous temperatures below 32°F (0°C) the use of an exterior chimney may result in operating problems such as poor draft and excessive condensation of combustion products. If you do install an exterior chimney we recommend that you install it within an insulated enclosure (see "

Outside Chase Enclosure" on page 17).

WARNING: THE CLEARANCE BETWEEN THE CHIMNEY AND COMBUSTIBLE MATERIAL MUST BE 2" OR MORE. DO NOT FILL THIS AREA WITH INSULATION.

OFFSETTING THE CHIMNEY

An elbow may be installed directly on top of the fireplace if required. Refer to Table 5 for the Offset Charts or to the RIS/EXCEL chimney installation manuals (icc-chimney.com/en/model-ris-support or icc-chimney.com/en/excel-technical-information).

Use the offset option if you need to clear a joist or pass around a cupboard. See Figure 14 for example.

Adding offsets to the chimney will increase the minimum required chimney height. Refer to Table 7 for specifics.

The maximum offset angle is:

- In USA: 30°
- In Canada: 45°.

The maximum number of elbows per system is four, resulting in two offsets and returns.

TABLE 5 OFFSET CHARTS

10" RIS						
Length between elbows	15° Offset		30° Offset		45° Offset	
	Rise	Offset	Rise	Offset	Rise	Offset
No length	11 7/8"	1 5/8"	14 1/8"	3 3/4"	15 7/8"	6 5/8"
12" length	22 1/4"	4 3/8"	23 3/8"	9 1/8"	23 1/2"	14 1/8"
24" length	33 7/8"	7 1/2"	33 3/4"	15 1/8"	32"	22 5/8"
48" length	57"	13 5/8"	54 5/8"	27 1/8"	48 7/8"	39 5/8"
48" + 12"	67 3/8"	16 1/2"	63 7/8"	32 1/2"	56 1/2"	47 1/4"
48" + 24"	79"	19 1/2"	74 1/4"	38 1/2"	65"	55 3/4"
48" + 24" + 12"	89 3/8"	22 3/8"	83 5/8"	43 7/8"	72 5/8"	63 3/8"
48" + 48"	102 1/4"	25 3/4"	95"	50 1/2"	82"	72 3/4"

8" EXCEL						
Length between elbows	15° Offset		30° Offset		45° Offset	
	Rise	Offset	Rise	Offset	Rise	Offset
No length	10"	1 1/4"	12"	3 1/4"	13 1/2"	5 1/2"
6" length	14"	2 1/2"	15 3/4"	5 1/4"	16 1/2"	8 1/2"
12" length	19 3/4"	4"	20 3/4"	8 1/4"	20 3/4"	12 3/4"
18" length	25 3/4"	5 1/2"	26"	11 1/4"	25"	17"
24" length	31 1/2"	7"	31 1/4"	14 1/4"	29 1/4"	21 1/4"
48" length	41 1/4"	9 3/4"	40 1/4"	19 1/2"	36 1/2"	28 1/2"
24" + 12"	54 3/4"	13 1/4"	52"	26 1/4"	46 1/4"	38 1/4"
48" + 12"	64 1/2"	16"	61"	31 1/2"	53 1/2"	45 1/2"
48" + 18"	70 1/4"	17 1/2"	66"	34 1/2"	57 3/4"	49 3/4"
48" + 24"	76 1/4"	19"	71 1/4"	37 1/2"	62"	54"
48" + 24" + 12"	86"	21 3/4"	80 1/4"	42 1/2"	69 1/4"	61 1/4"
48" + 48"	99 1/4"	25 1/4"	92"	49 1/2"	79"	71"



GOING THROUGH A WALL

If necessary, the chimney can go through a wall at an angle. You will need to use an Insulated Angled Wall Radiation Shield (RM-10WRSI30, RM-10RWSI45, XM-8EWRSI30 or XM-8EWRSI45) to protect the combustible wall structure from the heat of the chimney. See Table 6 for installation dimensions and minimum ceiling height.

TABLE 6 THROUGH THE WALL INSTALLATION DIMENSIONS

10" RIS		
	30° Offset Through the Wall US and Canada	45° Offset Through the Wall Canada Only
Minimum required ceiling height ✱ ✱	10' 4" (3,15 m)	8' 9" (2,67 m)
Height of the center of the hole in the wall ✱	8' 2¾" (2,51 m)	7' ¾" (2,22 m)
Minimum height of the hole	47 ½" (1,21 m)	32 ¾" (832 mm)
Position of the hole	Centered on the chimney coupling of the fireplace or on the fireplace casing	
Minimum width of the hole	16" (406 mm)	
8" EXCEL		
	30° Offset Through the Wall US and Canada	45° Offset Through the Wall Canada Only
Minimum required ceiling height ✱ ✱	10' (3,05 m)	8' 7" (2,62 m)
Height of the center of the hole in the wall ✱	8' (2,44 m)	7' 1½" (2,17 m)
Minimum height of the hole	43" (1,09 m)	31¼" (794 mm)
Position of the hole	Centered on the chimney coupling of the fireplace or on the fireplace casing	
Minimum width of the hole	14" (356 mm)	

✱ These heights assume that the first elbow is directly on the fireplace as depicted in Figure 16. If this is not the case, these heights have to be increase by the length of chimney installed on the fireplace before the first elbow.

✱ This minimum ceiling requirement is only for the chimney installation through a wall. It does take into account other aspects that might require a higher minimum ceiling height such as the HRS clearances.

OUTSIDE CHASE ENCLOSURE

If the chimney runs up the outside of the house, we recommend that it be enclosed in a chase structure. The chase should be constructed in such a way that it is an extension of the home (see Figure 15). It should be well insulated between the footings and the floor of the home to prevent heat loss. If the climate in your area is mild, insulate the chase at least to the first firestop. If the climate in your area is very cold, insulate the chase to the top to keep the chimney warmer, increase the draft, and reduce creosote buildup. We also recommend insulating the ceiling of the chase just as if it were in the attic space. This will prevent cold air from dropping down through the chase and into the room where the fireplace is installed (see Figure 15).

Some local codes require that the walls be insulated, vapor sealed and sheathed with a fire rated gypsum board (see Figure 15). We strongly recommend this procedure for all installations to prevent cold drafts from originating in the fireplace enclosure. If you follow this procedure, we recommend that you do not insulate the wall above the front of the fireplace.

REMEMBER: CHECK LOCAL CODES CONCERNING INSTALLATION REQUIREMENTS AND RESTRICTIONS IN YOUR AREA.

CHIMNEY HEIGHT

We recommend that the minimum height be increased by approximately 6" for every 1000' elevation above sea level. Every 15°, 30° or 45° offset (one pair of elbows) also increases the minimum height. See Table 7 for more precise recommended flue heights.

For example, if you are living 6015' above sea level, your chimney should terminate at least 15' from the top of the fireplace if it is a straight chimney or at least 18'6" if one 30° offset is used as shown in Table 7.

TABLE 7 RECOMMENDED MINIMUM FLUE HEIGHT

10" RIS							
Elevation (ft)	Number of Offsets						
	Straight Chimney	1 x 15°	2 x 15°	1 x 30°	2 x 30°	1 x 45°	2 x 45°
0 - 1000	minimum 12'	13'	14'	15'	18'	16'	20'
1001 - 2000	12'6"	13'6"	14'6"	15'6"	19'	16'6"	20'6"
2001 - 3000	13'	14'	15'	16'	19'6"	17'	21'6"
3001 - 4000	13'6"	14'6"	15'6"	17'	20'	18'	22'6"
4001 - 5000	14'	15'	16'	17'6"	21'	18'6"	23'
5001 - 6000	14'6"	15'6"	17'	18'	21'6"	19'	24'
6001 - 7000	15'	16'	17'6"	18'6"	22'6"	20'	25'
7001 - 8000	15'6"	16'6"	18'	19'	23'	20'6"	25'6"
8001 - 9000	16'	17'	18'6"	20'	24'	21'	26'6"
9001 - 10000	16'6"	17'6"	19'	20'6"	24'6"	22'	27'

8" EXCEL							
Elevation (ft)	Number of Offsets						
	Straight Chimney	1 x 15°	2 x 15°	1 x 30°	2 x 30°	1 x 45°	2 x 45°
0 - 1000	minimum 18'	19'	20'	21'	24'	22'	26'
1001 - 2000	18'6"	19'6"	20'6"	21'6"	25'	22'6"	26'6"
2001 - 3000	19'	20'	21'	22'	25'6"	23'	27'6"
3001 - 4000	19'6"	20'6"	21'6"	23'	26'	24'	28'6"
4001 - 5000	20'	21'	22'	23'6"	27'	24'6"	29'
5001 - 6000	20'6"	21'6"	23'	24'	27'6"	25'	30'
6001 - 7000	21'	22'	23'6"	24'6"	28'6"	26'	31'
7001 - 8000	21'6"	22'6"	24'	25'	29'	26'6"	31'6"
8001 - 9000	22'	23'	24'6"	26'	30'	27'	32'6"
9001 - 10000	22'6"	23'6"	25'	26'6"	30'6"	28'	33'

Flue height is measured from the top of the fireplace to the top of the chimney before installing the rain cap.

If you have two different offsets (two pairs of different elbows), simply use the column for two offsets of the biggest pair of elbows at your elevation to get your Minimum Flue Height.

FIREPLACE INSTALLATION

WARNING: IF THIS FIREPLACE IS NOT PROPERLY INSTALLED, A HOUSE FIRE CAN RESULT. FOR YOUR SAFETY, FOLLOW THE INSTALLATION INSTRUCTIONS AND CLEARANCES. DO NOT PACK REQUIRED AIR SPACES WITH INSULATION OR OTHER MATERIALS.

UNPACKING YOUR LINEAR 50 SP

The fireplace crate includes the following:

- (A) Fireplace in transportation configuration (approximately 950 lb)
- (B) Two bottom standoffs
- (C) Spark guard
- (D) Four anti-tip stability brackets: attached to the top of the fireplace casing
- (E) In the manual bag (attached to the side of the fireplace casing):
 - One bag with 16 large self-tapping screws (1")
 - One bag with 6 small self-tapping screws (½") and 6 flat washers
 - An owner's manual
 - One bag with 16 black screws (1¼")
 - A 5" external air coupling
 - An installation manual
- (F) Two air intake frames
- (G) Two air outlet grills (¼" thick aluminum)
- (H) Two outlet adapters (pre-installed in flexible duct)
- (I) Two 10" diameter insulated flexible ducts

All these items will be referred to by the above letters throughout the installation instructions of the fireplace itself.

MOVING THE LINEAR 50 SP

WARNING: THE FIREPLACE IS HEAVY. ALWAYS MAINTAIN CONTACT WITH THE FIREPLACE WHEN MOVING IT TO PREVENT ANY UNDUE TILTING.

The fireplace arrives with two transportation handles, one on each side of the fireplace. They are solidly attached and can be used to lift and transport the fireplace without the pallet. Moving straps or dollies can also be used. Always handle the fireplace by its casing. The LINEAR 50 SP's main body weighs 940 lb. as shipped.

To reduce the weight, remove everything inside the firebox, including the refractory bricks and insulation panel. The crating, bottom standoffs, glass door and both glass panels can also be removed to bring the total weight down to 480lbs (460lbs less).

You can use an Escalera to move the fireplace. If you do, make sure to position the attachment straps at the locations shown in Figure 6. Do not put the attachment straps anywhere else or you could damage the fireplace by doing so.

If you decided to remove the refractory bricks and the insulation panel, follow the refractory bricks installation section (see page 30) in the reverse order to remove all the refractory bricks and the insulation panel. Make sure to close the glass door and lock it in place.

INSTALLING THE BOTTOM STANDOFFS

Ensure floor requirements are met. Refer to page 13.

1. Start by positioning the two bottom standoffs (B) on the floor, centered in the framing and against the back wall. Slide the spark guard (C) under the front of the bottom standoffs as shown in Figure 7. Refer to the "Hearth Extension" section on page 28 for additional information.
2. Using at least 1½" wood screws (not provided) solidly attach both bottom standoffs to the floor. If possible, attach the bottom standoff to the floor joists below using 3" wood screws (not provided).
3. Refer to "Lifting the Fireplace" for assistance in raising the fireplace above the bottom standoffs. Install it on the fireplace bottom standoffs making sure that the base of the fireplace is centered with the bottom standoffs.

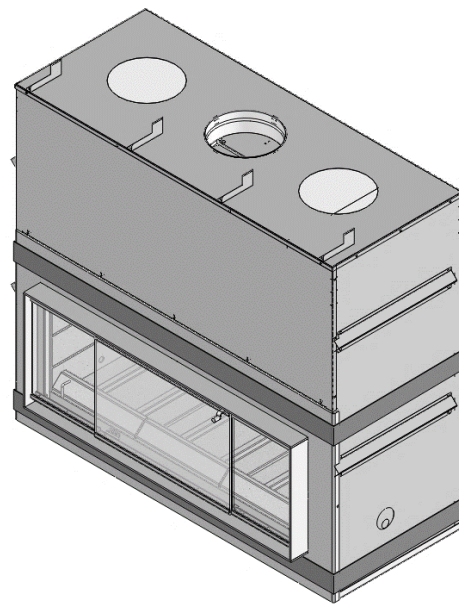

Both straps must be on the black facing of the fireplace: one above and one below the lintels

FIGURE 6 ATTACHMENT STRAPS LOCATION

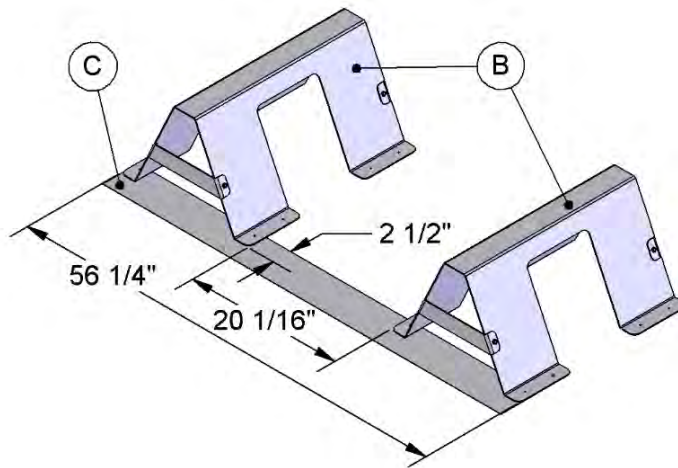

FIGURE 7 POSITIONING AND INSTALLING THE FIREPLACE BOTTOM STANDOFF AND CASING

LIFTING THE FIREPLACE

The LINEAR 50 SP weighs approximately 950 lb as shipped. One effective method to raise it above the bottom standoffs is to connect a chain or strap to the four transportation handles located on the sides, then use a hoist or come-along winch to raise the fireplace. The hoist should be secured to a structural beam or joist to ensure it is secure.

SECURING THE FIREPLACE

The fireplace MUST be solidly attached to the back wall.

You MUST install two anti-tip stability brackets (D) at the top of the fireplace. They must be solidly screwed to the back wall and to the top of the fireplace. Depending on your specific installation, you can install the anti-tip stability brackets in two different ways. Refer to Figure 8 for examples of installation of the anti-tip stability brackets. Use eight of the large self-tapping screws provided (E) to attach both anti-tip stability brackets to the top of the fireplace casing.

You also MUST to install one anti-tip stability brackets (D) on each side of the fireplace casing, just a couple of inches above the bottom casing. They must be solidly screwed to the back wall. Use eight of the large self-tapping screws provided (E) to attach both anti-tip stability brackets to the sides of the fireplace casing.

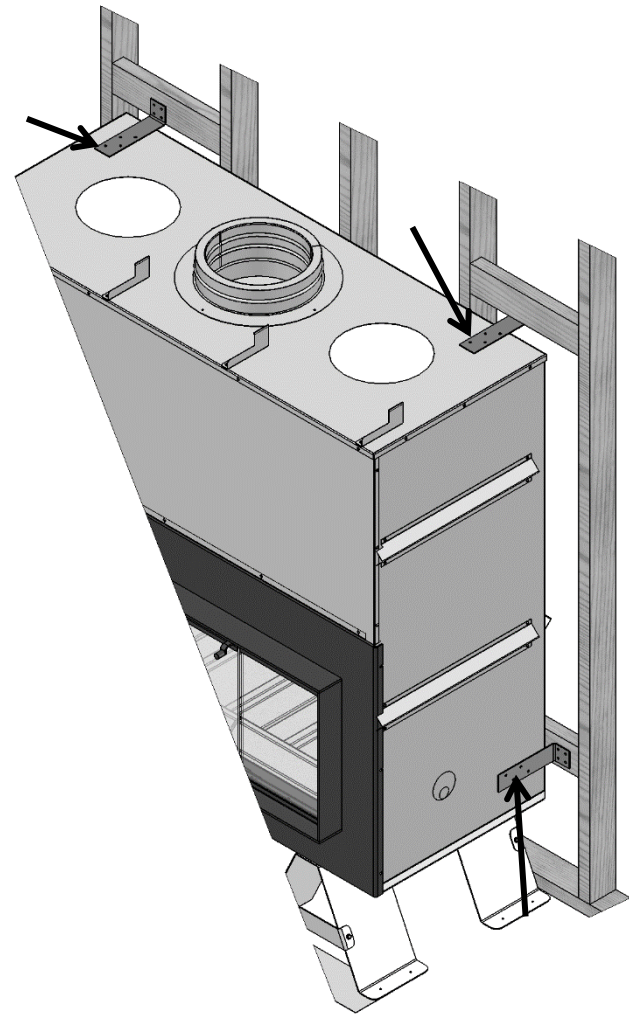

FIGURE 8 ANTI-TIP STABILITY BRACKET INSTALLATION

HEAT REDISTRIBUTION SYSTEM (HRS) INSTALLATION

HRS AIR INTAKES

The HRS Air Intake provided with the fireplace consists of two black rectangular frames with a grill at the front (see Figure 9). Both air intakes must be installed so that they permit air into the bottom portion of the fireplace enclosure. The air intakes do not connect directly to the fireplace, but will provide the fireplace with the air necessary to maintain a safe installation.

1. On the sides or front of the fireplace, frame two 12" wide by 7" high openings for the installation of each air intake. The air intakes are designed to be installed on top of the cement board/drywall. We recommend that the hole be framed for a sturdier installation, but you can also use gypsum anchors behind the air intakes to secure the four screws.
2. Once the wall is covered with cement board/drywall, insert the air intakes (F) into the opening and attach the grill with the black screws (E) provided in the corner holes.

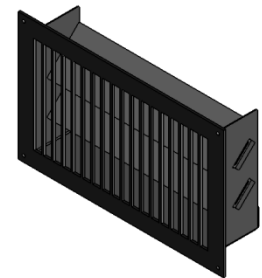

FIGURE 9 HRS AIR INTAKE

WARNING: ONLY USE GRILLS CERTIFIED BY RENAISSANCE FIREPLACES. SUBSTITUTING THE GRILLS PROVIDED WITH THE FIREPLACE OR FIREPLACE OPTIONS WILL RESULT IN LOSS OF WARRANTY AND POSE A FIRE HAZARD.

DO NOT BLOCK AIR FLOW IN FRONT OF THE INTAKE GRILLS. YOU MUST ALLOW FREE AIR MOVEMENT.

The HRS air intakes are now ready for operation.

HRS AIR OUTLETS

The HRS Air Outlets distribute the heated air that was drawn into the air intake and circulated through the fireplace. The HRS Air Outlets consist of:

- Two air outlet grills (G),
- Two outlet grill adapters (H) (pre-installed in duct), and
- **Two 10" flexible insulated ducts (I).**

Refer to Figure 10 to identify the various parts.

WARNING: NO SUBSTITUTION OF CERTIFIED RENAISSANCE PARTS AND OPTIONS IS PERMITTED.

CERTIFIED RENAISSANCE PARTS PROVIDE THE CORRECT CLEARANCES. THESE CLEARANCES MUST BE MAINTAINED FOR YOUR SAFETY. EVERY MEASUREMENT AND CLEARANCES MUST BE FOLLOWED CAREFULLY.

WARNING: DO NOT BLOCK AIR FLOW IN FRONT OF THE OUTLET GRILLS. YOU MUST ALLOW FREE AIR MOVEMENT.

WARNING: FRAMING OF THE RECTANGULAR GRILL OUTLET MUST BE COMPOSED OF NON-COMBUSTIBLE MATERIALS.

THE WALL SURFACE AROUND THE RECTANGULAR AIR OUTLET MUST BE COMPOSED OF NON-COMBUSTIBLE MATERIALS.

1. Attach the round end of the insulated flexible duct (I) to the HRS outlet starter on the fireplace (see Figure 10). Ensure the insulated flexible duct completely covers the HRS outlet starter protruding above the top of the fireplace. Using three of the self-tapping screws with three flat washers provided (E), screw through the insulated flexible duct to attach it to the HRS starter.
2. Extend the insulated flexible duct as desired. You may need some plumber's strapping to support the duct if it runs horizontally. To extend the duct beyond the 5' provided, additional 5' lengths can be ordered with the part code EO-DUCT.

WARNING: ALL SPECIFICATIONS AND CLEARANCES IN TABLE 2 MUST BE RESPECTED.

BOTH DUCTS MUST TERMINATE AT THE SAME HEIGHT, AND THEY MUST NEVER SLOPE DOWNWARDS.

3. Using steel studs, install a header at the location and height you wish to mount the air outlet grills. Refer to Figure 11 for framing requirements.

4. Attach the outlet grill adapters (H) that are pre-installed in the duct to the steel stud header.
5. Install a second steel stud to frame the grill adapters on top and bottom as shown in Figure 11.

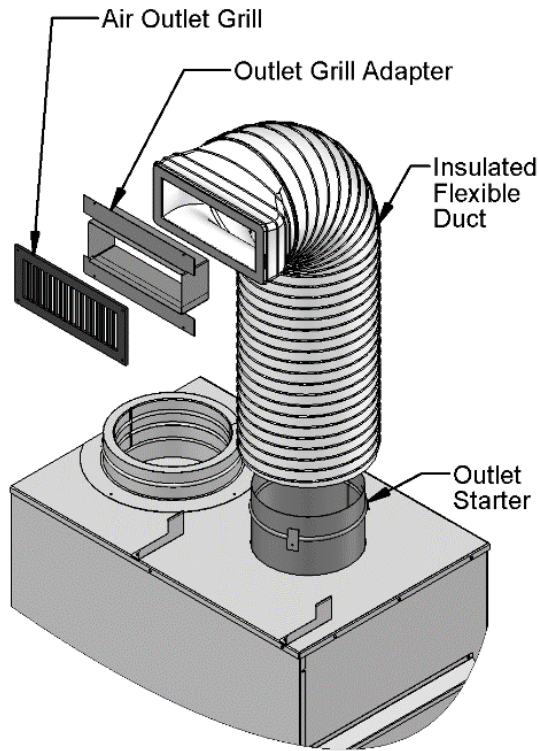

FIGURE 10 HRS AIR OUTLET GENERAL INSTALLATION

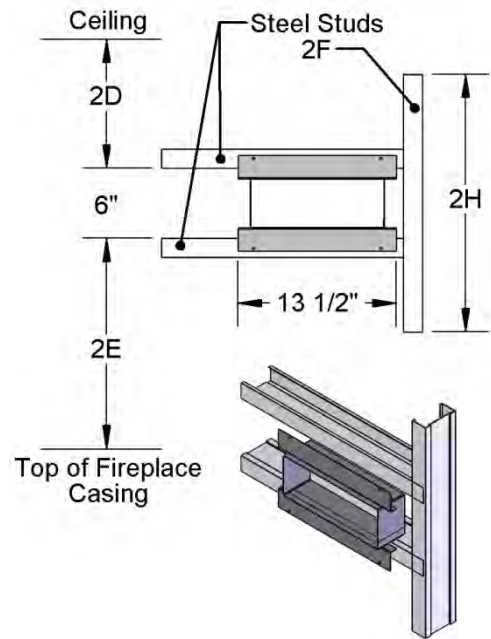

FIGURE 11 HRS OUTLET FRAMING AND CLEARANCES

6. When ready, cover the wall with cement board. The **outlet grill adapters have a 1/2" lip for the cement board to butt against.**
7. Screw the air outlet grills (G) to the wall with the black screws provided (E).

See Figure 12 for an example.

The HRS outlets are now ready for operation.

OUTSIDE AIR DUCT

After the fireplace is correctly positioned, connect the outside air intake of the fireplace to the outside of the house (see Figure 13).

Use an insulated aluminum flexible duct rated at over 200°F (93°C) (not provided). The duct should not exceed 12' vertical rise above the base of the bottom standoff.

The outside air intake **MUST** be at least 5' below the top of the chimney flue and must never terminate in an attic space.

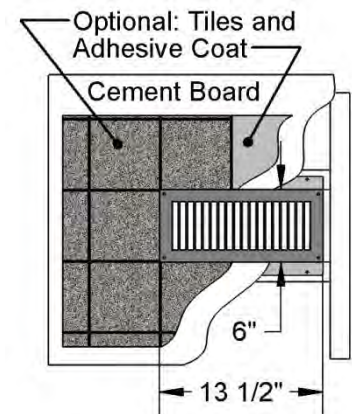

FIGURE 12 HRS OUTLET FINISHING

CAUTION: WHEN RUNNING THE DUCT AROUND CORNERS, AVOID CRUSHING THE DUCT, WHICH CAN RESTRICT THE COMBUSTION AIRFLOW.

A 4" diameter duct can be used if the total duct run is less than 25'. We recommend the FO-INT outside air kit. For longer runs, use 5" diameter duct. Both 4" and 5" connecting sleeves are provided with the fireplace

1. Find a convenient location for the outside air intake. The outside air intake can be above or below floor level.
2. Make a 4 ¼" (5 ¼" if using a 5" diameter duct) hole in the outside wall of the house. Push the round sleeve of the outside air hood in from the outside. Seal the joint between the air hood and the outside wall with an appropriate sealant.

3. Place the insulated flexible duct over the round sleeve on the outside air hood. At both ends, carefully pull back the insulation and plastic cover, exposing the flexible duct. Then at each end, attach the duct with metal screws to the air hood sleeve and to the fireplace connecting sleeve. Carefully push the insulation and cover back over the duct. Tape the plastic cover in place with 2" aluminum duct tape.

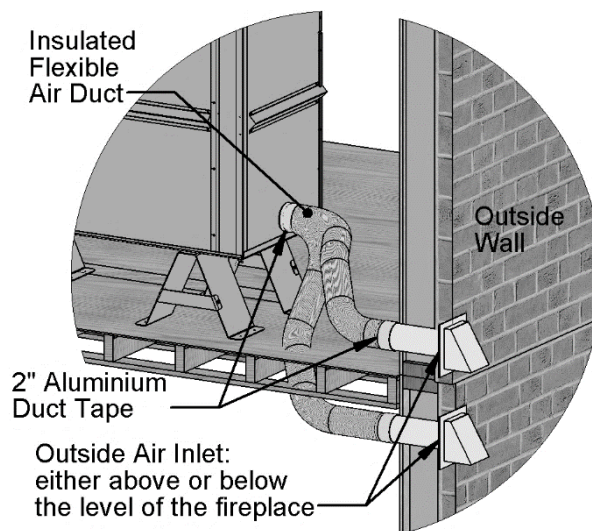

FIGURE 13 OUTSIDE AIR CONNECTION AND INSTALLATION EXAMPLE

CHIMNEY INSTALLATION

Read the RIS/EXCEL Chimney installation manual concerning requirements for supports, bracing, anchoring, etc. It can be found online at: <http://icc-chimney.com/en/model-ris-support> or <http://icc-chimney.com/en/excel-technical-information>. Refer to Table 4 (D) for the maximum chimney height that can be supported by the top of the fireplace.

WARNING: THE CLEARANCE BETWEEN THE CHIMNEY AND COMBUSTIBLE MATERIAL MUST BE 2" OR MORE. DO NOT FILL THIS AREA WITH INSULATION.

1. Cut and frame the required holes in the floor(s), ceiling(s) and roof where the chimney will pass through. The rough opening in the framing is 16" square (the opening can be slightly bigger, up to 16 ½", but NEVER smaller) if using 10" RIS chimney or 14" square (the opening can be slightly bigger, up to 14 ½", but NEVER smaller) if using 8" EXCEL chimney.
2. At each floor where the chimney passes through, you must install a radiation shield. At the attic level, install a radiation shield and a storm collar as shown in Figure 4.

WARNING: A RADIATION SHIELD MUST BE INSTALLED AT EACH FLOOR WHERE THE CHIMNEY PASSES THROUGH.

3. Start by installing the appropriate flue adapter on the fireplace: EO-10SPAP for the 10" RIS chimney or the EO-08SPAP for the 8" EXCEL chimney.

4. Install the first chimney length on top of the flue adapter of the fireplace and secure it with the screws provided. Continue adding lengths and supports as required until the chimney penetrates the roof deck or top of the chimney chase.

The chimney must extend at least 3' above its highest penetration of the roof and at least 2' higher than any wall, roof, or building within 10' horizontally of it. If the chimney extends higher than 5' above the roof, it must be secured using a roof brace.

5. At the roof, install a roof top shield.
6. Put the roof flashing into place. Seal the joint between the roof and the flashing with roofing tar. For sloping roofs, place the flashing under the upper shingles and on top of the lower shingles. Secure the flashing to the roof with roofing nails or screws.

If the chimney is enclosed to the roof: use a vented flashing.

If the chimney is not enclosed in the attic: use a regular flashing.

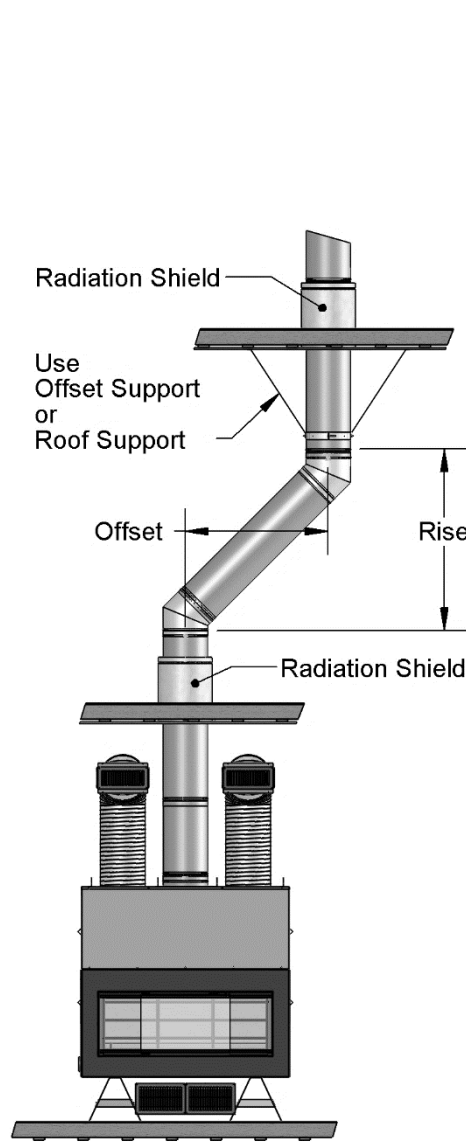

FIGURE 14 OFFSET CHIMNEY INSTALLATION EXAMPLE

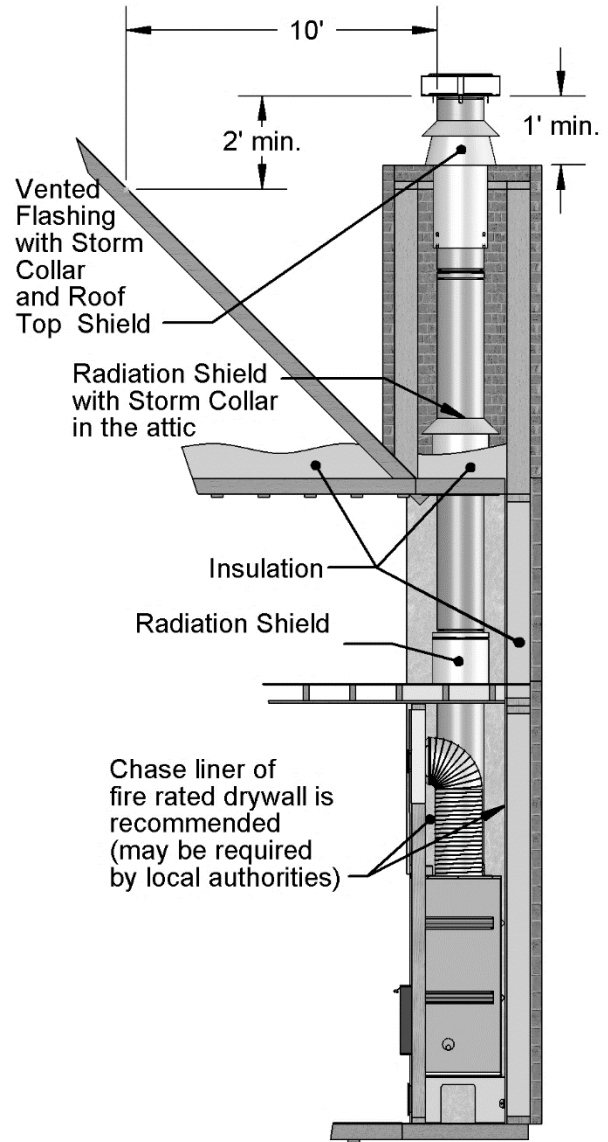

FIGURE 15 CHIMNEY INSTALLED WITH AN OUTSIDE CHASE ENCLOSURE EXAMPLE

7. Place the storm collar over the chimney and flashing. Seal it around the chimney with silicone sealer (DO NOT use roofing tar).
8. Fit the rain cap on the chimney. Secure it tightly in place with the screws provided.

TO OFFSET THE CHIMNEY

Install the fireplace and chimney as described earlier. When you require an elbow, proceed as follows:

1. Install the elbow. Turn it in the desired direction and fasten it to the other section with 4 metal screws at the joints.
2. Install enough lengths to obtain the desired offset. Secure each joint with 4 metal screws.
3. Use another elbow to return the chimney to the vertical direction. Again, fasten it to the other section with 4 metal screws at the joints.
4. Install a roof support, a wall support, or an offset support above each offset to support the weight of the chimney (elbows are not designed to support the chimney above an offset).

THROUGH THE WALL OFFSET

You can also go through a wall at an angle starting directly at the fireplace as depicted in Figure 16. An angled wall insulated radiation shield (RM-10WRSI30, RM-10RWSI45, XM-8EWRSI30 or XM-8EWRSI45) must be used wherever the chimney passes through a wall.

Refer to Table 6 for dimensions pertaining to the installation of the angled wall insulated radiation shield (RM-10WRSI30, RM-10RWSI45, XM-8EWRSI30 or XM-8EWRSI45). Make sure to have enough ceiling height for your installation. If the ceiling height is too low for the planned installation you may want to consider installing the fireplace in an outside chase.

If the chimney is enclosed once outside of the house, do not install the outside plate of the angled wall insulated radiation shield.

Refer to the angled wall insulated radiation shield installation sheets for detailed installation instructions.

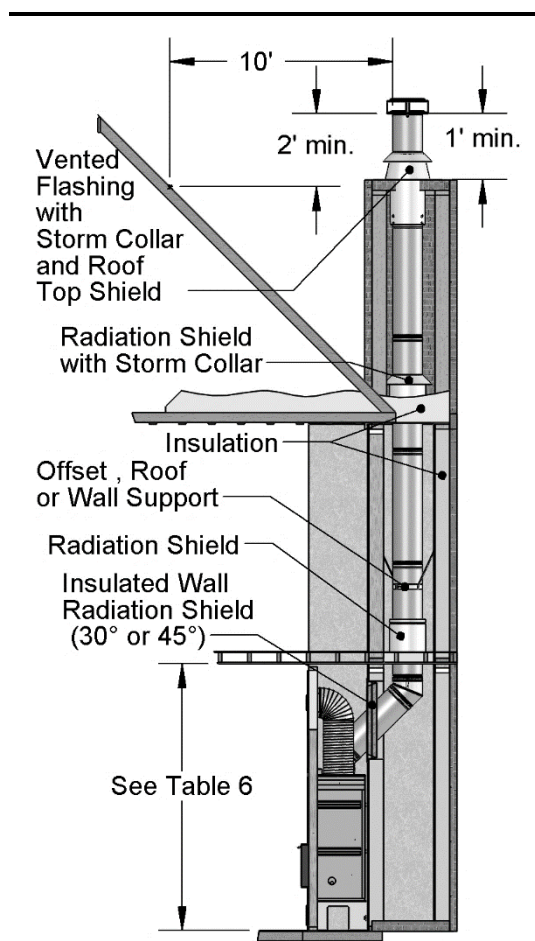

FIGURE 16 OFFSET CHIMNEY
 THROUGH A WALL
 EXAMPLE

FINISHING

FIREPLACE FACING

The LINEAR 50 SP MUST be covered with at least ½" cement board panels such as James Hardie HardieBacker® or USG Durock® cement boards. Either product will then allow you to finish the facing of the fireplace with any non-combustible material you like.

WARNING: DO NOT USE GYPSUM BOARDS.

INSTALLING THE CEMENT BOARD PANELS

The entire front of the fireplace up to the framing around it MUST be covered by the cement boards. Refer to Figure 17 for recommended minimum dimensions for the various cements panels to be prepared and installed.

Make sure to use 1" screws and only screw where specified in Figure 18.

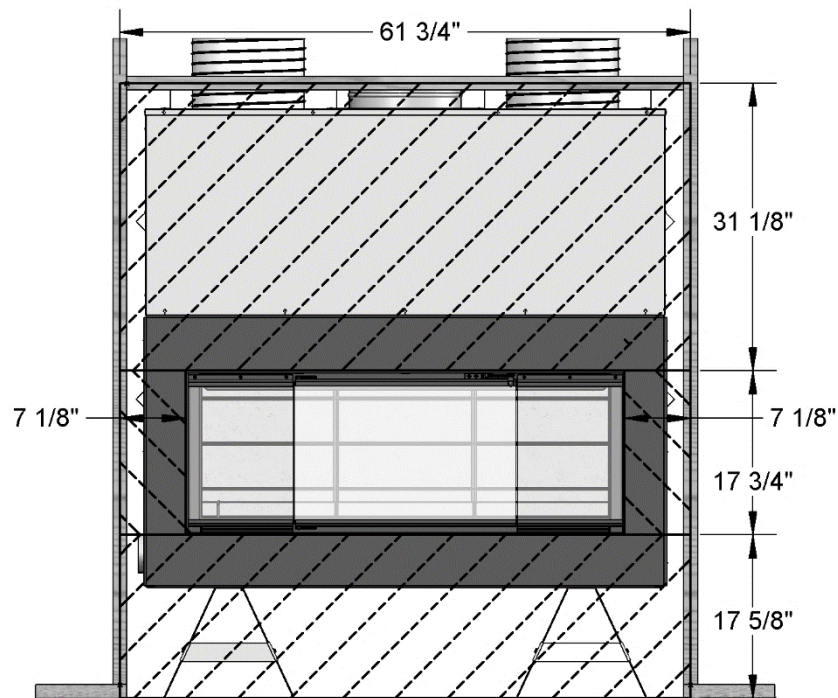

FIGURE 17 CEMENT BOARD PANELS MINIMUM DIMENSIONS

COVERING THE FIREPLACE FACING

Facing materials must be NON-COMBUSTIBLE such as metal, brick, slate or ceramic tile. Gypsum board is NOT an acceptable facing material. The only combustible material accepted on the facing of the fireplace is for a mantel shelf.

The cement boards can be painted, textured or tiled just as you would over gypsum boards. The lintels provided with the fireplace are not meant to support heavy facing materials. Heavy facing materials should be supported as if there were no lintels on the fireplace.

If you need to attach anything to the front of the fireplace, refer to Figure 18 to know where you are allowed to screw. Use screws that penetrate the front surface of the cement boards by no more than 1".

CAUTION: IF ABSOLUTELY NECESSARY, YOU CAN SCREW INTO THE CEMENT FACING ELSEWHERE AS LONG AS THE SCREW TIP DOES NOT COMPLETELY PENETRATE THE $\frac{1}{2}$ " CEMENT BOARD PANELS.

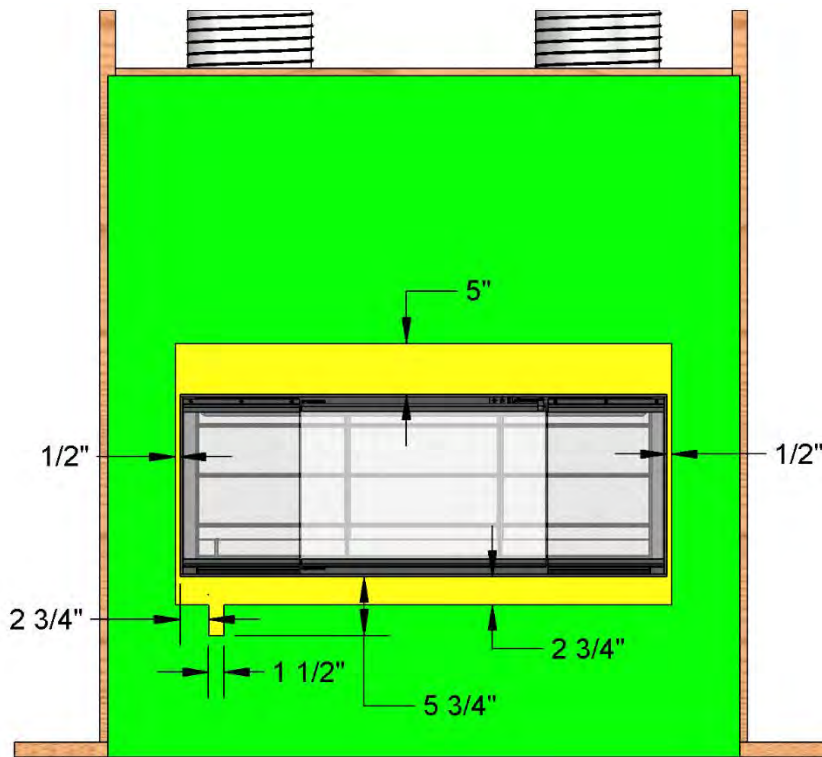

- Appropriate to attach the cement boards. The screws will grab into the metal of the finishing covers offering more strength.
- Not for cement board attachment. The screws will only be attached to the cement panels at the front.

FIGURE 18 PERMISSIBLE SCREWS AREAS

HEARTH EXTENSION

The area immediately in front of the fireplace must be protected if the surface is combustible. Refer to Table 1 (E-F) for the depth and width that the hearth extension protection should extend beyond the front and both sides of the fireplace opening (see Figure 2). Refer to Figure 19 for various alternatives of hearth extension installation.

The protection required for combustible flooring in front of the fireplace includes:

1. Spark Guard

The spark guard provided (C) must be installed 2½" under the fireplace bottom standoff and 2½" under the hearth extension, centered on the fireplace opening (see Figure 19). This guard prevents sparks from lodging in this area and starting a fire.

If you are installing the fireplace on a raised combustible platform, you will need a second spark guard (not provided) with the same dimensions as the one we have provided. One spark guard will be installed at the floor, below the hearth extension and the raised platform. The second spark guard will be installed at the base of the fireplace itself. Both spark guards must be centered on the fireplace opening.

Non-combustible flooring material such as brick, tile, stone, or slate must be used as finishing material over the hearth extension area.

The non-combustible flooring material must have the same minimum dimensions as the hearth extension (see Table 1 (E-F)).

If the LINEAR 50 SP is installed on a non-combustible floor, none of the protection above is needed.

RAISED HEARTH EXTENSION

It is allowed to have a raised hearth extension as long the materials used to make the structure and to cover it are all non-combustible such as steel studs, cement blocks, etc. No combustible materials are allowed above the floor level on which the bottom standoff resides below the fireplace.

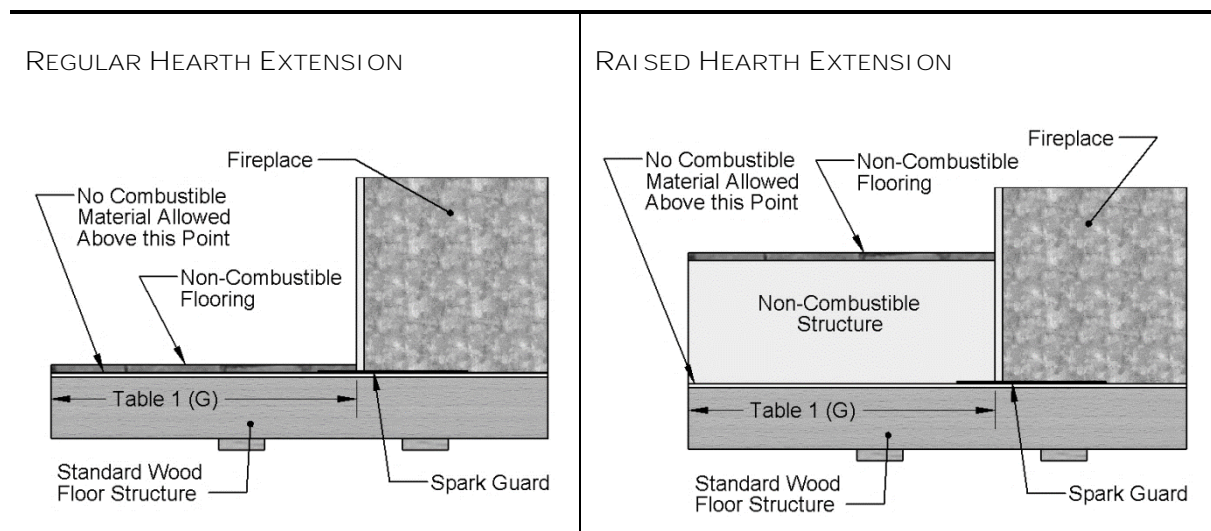

RAISED FIREPLACE HEARTH EXTENSION

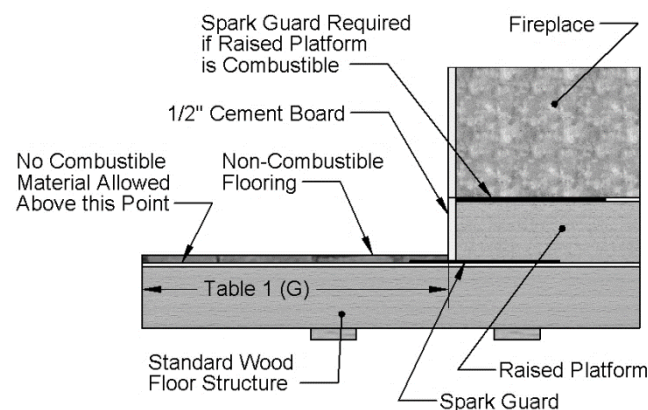

FIGURE 19 HEARTH EXTENSION EXAMPLES

MANTEL

Masonry and other non-combustible mantels (shelf and posts) can be placed anywhere around the fireplace opening.

For combustible mantel shelves, please see Table 3 (A-B) for the maximum depth and its installation clearance requirements. See Figure 2 for an example.

Vertical mantel posts on the sides of the fireplace opening must be non-combustible. Combustible mantel posts are not permitted unless they meet the clearance required to a perpendicular sidewall (see Table 1 (C)).

The only combustible material accepted on the facing of the fireplace is for a mantel shelf.

If you need to attach the mantel to the front facing of the fireplace, refer to page 27 to know where screws are permitted on the front of the fireplace facing.

FIREBOX LINING INSTALLATION

The refractory bricks and insulation panel of the LINEAR 50 SP fireplace are placed in the fireplace at the factory. If, for any reason, they should need to be replaced, the following order should be observed. To remove any of the refractory bricks, just follow the installation procedure in the reverse sequence. Refer to Figure 20 to adequately identify each component at each step of the installation.

If you have removed the refractory bricks and the insulation panel to facilitate moving the fireplace, you must make sure they are properly installed inside the firebox before making your first fire. This is easily accomplished with the following instructions.

1. First install the left refractory brick, placing it as forward as possible.
2. Then do the same for the right side.
3. Then install the three back refractory bricks. Be careful to slide them under the supports at the top of the back of the firebox. Take the time to center them, leaving a small gap between each.
4. There is a piece of soft insulation that goes on the bottom of the firebox. It is cut tight so place it at the front first then push it down at the back. It will fit snugly in between the back and side refractory bricks.
5. You can then place the three bottom bricks. Again, take the time to center them, leaving a small gap between each.

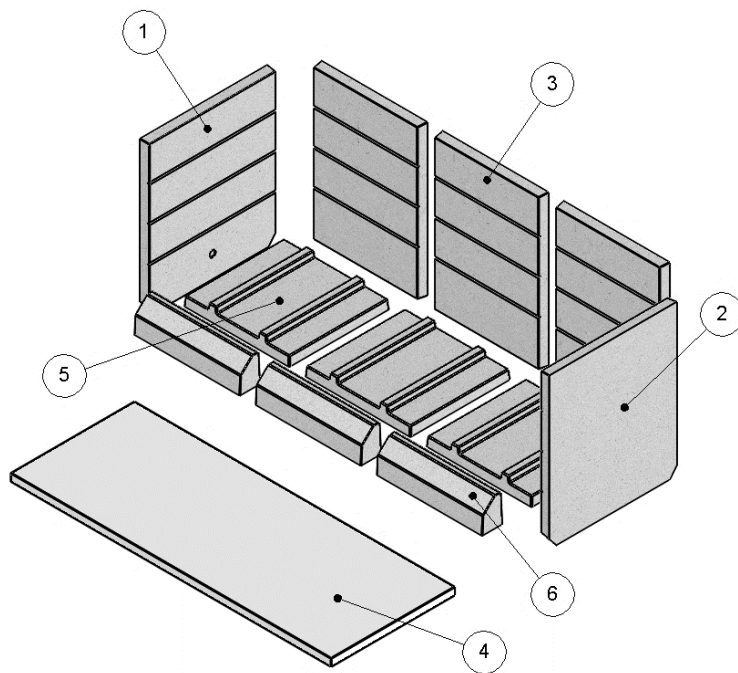

FIGURE 20 REFRACTORY BRICKS AND INSULATION PANEL

6. Finish by placing the three ash step refractory bricks. Make sure to place them with the angled side towards you.

WARNING: THE FIREPLACE SHOULD NEVER BE BURNED WITHOUT THE FIREBOX INSULATION AND REFRACTORY BRICKS PROPERLY INSTALLED.

GLASS CLEANING

If the glass needs cleaning after installation is complete, use a glass cleaner specifically formulated for wood stove ceramic glass. Do not use an abrasive cleaner and do not clean the glass while it is hot. You may want to recommend a wood stove glass cleaner to the owner.

REPLACEMENT PARTS

A complete list of replacement parts is available on our web site: www.renaissancefireplaces.com

WARRANTY

30 YEAR LIMITED WARRANTY FOR RENAISSANCE FIREPLACES™

All Renaissance Fireplaces™ models are warranted against defects in material and workmanship for a period of 30 years, subject to the following conditions:

During the first year Renaissance Fireplaces™ will repair or replace, at our option, any parts which upon examination by an authorized Renaissance Fireplaces™ representative, are found to be defective, except the parts listed in the EXCLUSIONS portion of this warranty. Renaissance Fireplaces™ will also pay reasonable labor costs for the repair work.

During the second through fifth years Renaissance Fireplaces™ will repair or replace, at our option, any parts which upon examination by an authorized Renaissance Fireplaces™ representative, are found to be defective, except the parts listed in the EXCLUSIONS portion of this warranty. Renaissance Fireplaces™ shall not be responsible for any labor costs associated with this repair work.

During the sixth through thirtieth years Renaissance Fireplaces™ will provide replacement parts, if available, at 50% of the published retail price, except for the parts listed in the EXCLUSIONS portion of this warranty. Renaissance Fireplaces™ shall not be responsible for any labor costs associated with this repair work.

EXCLUSIONS:

- Glass.
- Damage due to normal wear and tear, such as paint discoloration, worn gaskets, eroded or cracked rigid insulation panels or firebox lining components.

- Repairs or replacements necessitated by vandalism, neglect, abuse, over-firing, improper fuel or fuel loads, or failure to adequately service the unit, as stated in the owner's manual.
- Repairs or replacements (particularly charges for travel and labor) not authorized by **Renaissance Fireplaces™** in advance.

LIMITATIONS:

- All items found to be defective will be replaced or repaired upon return of the defective part to an authorized **Renaissance Fireplaces™** dealer. **Renaissance Fireplaces™** will not be responsible for freight costs related to shipping replacement parts.
- Any complete fireplace, or part thereof, that is replaced or serviced under this warranty, will be warranted for a period not exceeding the remaining term of the original warranty.
- This warranty is not transferable.
- This warranty does not apply to damage to the appliance while in transit.
- This warranty does not apply if the installation does not conform to the installation requirements in the installation and owner's manuals.
- **Renaissance Fireplaces™** is free of liability for any damages caused by the appliance, as well as material and labor charges incurred in the removal or re-installation of any **Renaissance Fireplaces™** fireplace under this warranty. Incidental or consequential damages are not covered by this warranty.
- The remedies set forth herein are exclusive, and the liability of the seller shall not exceed the price of the fireplace or part thereof upon which the liability is based.
- This warranty is expressly in lieu of all other warranties expressed or implied, including the warranties of merchantability and fitness for use and all other obligations or liabilities on the part of **Renaissance Fireplaces™**.